

A blurred, high-speed photograph of a train moving through a tunnel. The train is red and yellow, with motion blur creating streaks of light and color. The tunnel walls and ceiling are also blurred, emphasizing the speed. The overall scene is dynamic and modern.

SIEMENS

[siemens.com/mobility](https://www.siemens.com/mobility)

Increasing energy efficiency

Optimized traction power supply in mass transit systems

From virtuality to reality



Electrification solutions that pay

Safeguarding mobility is one of the big challenges facing our society today. To ensure our mobility in future, we need networked transport and information systems. But we will only be able to meet these mobility requirements through efficient coordination and perfect meshing of all modes of transport.

This is why Siemens – with its “Complete mobility” approach – is offering integrated transport and logistics solutions for safe, cost-effective and environment-friendly passenger and freight services. For Siemens has the necessary competence to provide everything from infrastructure systems for railways and roadways to solutions for rolling stock, airport logistics and postal automation.

Key elements of “Complete mobility” are efficient solutions for rail-based transport systems for cities and population centres and for connecting large cities and countries.



IMPLEMENTATION



PLANNING

A HOLISTIC ELECTRIFICATION PROCESS

Thanks to our defined and holistic process, we ensure transparency and clarity in each phase of a project. In three steps, we help you to analyze your needs, plan your individual configuration and then concretely implement your tailor-made electrification solution.

Virtuality | 1

Siemens is one of world's leading suppliers of innovative railway electrification systems. The design and calculation of installations are among our core areas of competence. System know-how and the latest IT tools enable us to achieve a precise definition of your particular needs.



Profitable analyses

It's good that we're so calculating. After all, the complex requirements involved in the creation of an economically efficient and stable electrification system call for an in-depth analysis. Our experts work with the latest software modules and apply the experience they have gained from decades devoted to the development of such solutions worldwide.

Providing advice and finance:

A good starting basis for growth

Our highly competent engineers and partners provide you with advice on all aspects of planning and system configuration from the very beginning. With our global network of innovation, we not only look beyond our own field of technology know-how but also have local needs closely examined by our worldwide network of on-the-spot experts. This enables a flexible variance analysis to be obtained on an international level. We consult with you closely to define the general parameters of the project right from the very first consulting session. To this end, we draw up an individual financing concept that is tailored to your situation and developed in close cooperation with local authorities, government offices and commercial banks all over the world.

ANALYSIS

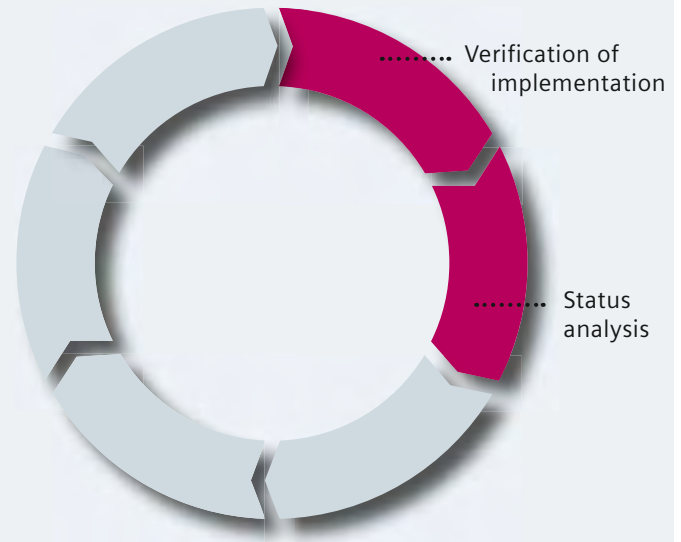

Data acquisition:

The value added is in the details

Irrespective of the infrastructure, topography or climate, our experts collect your data straight from the actual source. In doing so, they are making use of data that is already available. However, it is frequently necessary to obtain new data as well in order to reliably evaluate the viability of a planned project. We carry out specific software-supported analyses, the results of which are incorporated as important parameters in the project simulation.

First planning unit:

Laying the foundations for decisions

With our Sitras® Sidytrac software tool, our experts generate crucial advantages that work out to your benefit. In an early phase of cooperation, you decide on the quality of the solution and the continuation of the project. On the basis of the acquired data, we draw up an initial project outline that allows alternatives at any time and thus creates a solid basis for a concrete offer to be made to you.

The result:

The right solution for the job in hand

Our extensive system know-how is based on the latest results from research and development by the relevant sections within Siemens as well as on our ability to draw the right conclusions from the calculations performed by our IT tools. These factors combine to ensure an optimal result ideally suited to satisfy your requirements.

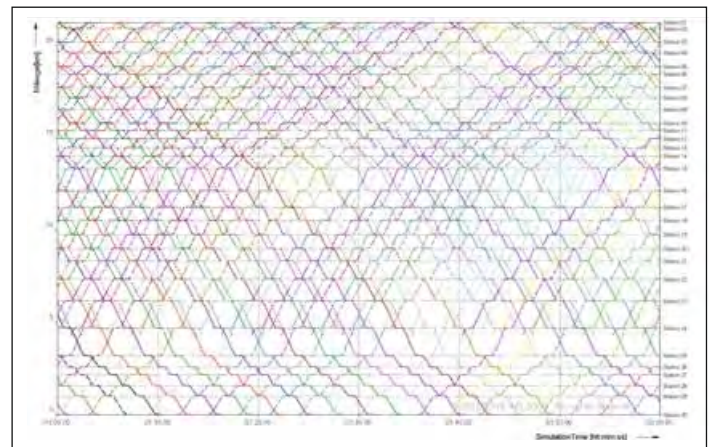

Sample calculation: Payback period

The energy saved with Sitras TCI can give a return on investment in just three years.



Virtuality | 2

Efficient railway electrification systems are the result of exact planning. Long before work is started on site, we simulate your individual project under realistic conditions on the computer. This saves you from any surprises and allows us to take all contingencies into consideration.

Planning is knowing what the result will be

We always consider a project from a holistic point of view. Our experts plan your traction power supply system embedded in a larger context. On the basis of the data obtained and taking into account your special needs, we incorporate the relevant infrastructural parameters into the simulation of your system from

the very beginning. As regards energy efficiency, the potential for savings can thus be determined as early as the first stages of calculation. This ensures a configuration that is both individual and easy on resources.



Sitras Sidytrac:

A little less, if you please?

Sitras Sidytrac is a simulation software that enables us to carry out an exact power-system calculation with train operation simulation for your particular project. In addition, workflows are standardized and automated, which means sources of error can be reduced and efficiency increased considerably. And that is regardless of whether you need a completely new system concept or simply want to know your existing system's potential for improvement. The software calculates your individual configuration and even goes a step further: due to the optimization of power consumption, power recovery behaviour and energy-saving potential, your resulting traction power supply system is not only exemplary in terms of ecology but also offers the beneficial side effect of substantially reduced lifecycle costs.

The following additional aspects of your system can be simulated and planned with Sitras Sidytrac:

- The electromagnetic compatibility of your planned installation or the parts of the installation to be upgraded.
- An earthing concept that guarantees optimum protection for people and electrical equipment.
- The network reaction and voltage quality based on the analysis of
 - system interactions due to harmonics
 - three-phase imbalance because of single-phase railway loads
 - voltage fluctuations and flicker
 - resonance behaviour of line sections under realistic operating conditions.

Concrete planning procedure:

Energy efficiency in three steps

Sitras Sidytrac wins over customers with its three-part program structure composed of input block, calculation block and output block. The input block is used to process the line data, the timetable, the vehicle data and the data of the electrical power supply system.

The calculation block is the heart of Sitras Sidytrac. First of all, the speed profile program calculates the location of the vehicles in the power supply network as well as the power they consume and deliver. These electrical loads are then incorporated in the static network and provide the basis for calculation of the dynamic electrical network. Then, the system determines the electrical load flow and incorporates the values in the speed profile.

The electrical data for the detailed design of the main components are finally evaluated in the output block. The results can then be shown in the form of predefined lists and graphics and stored in a database.

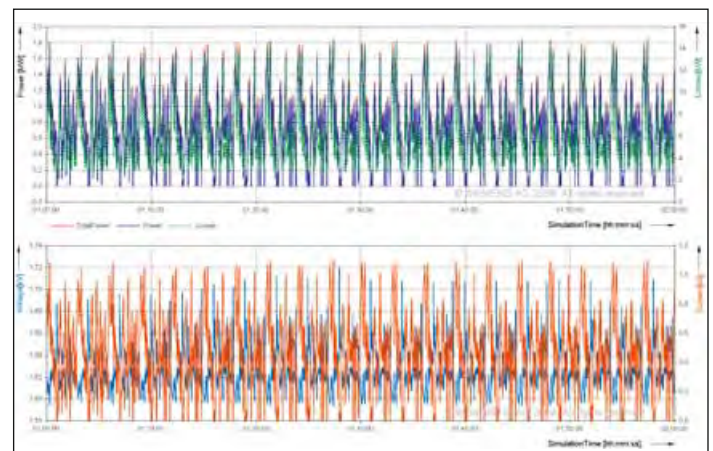
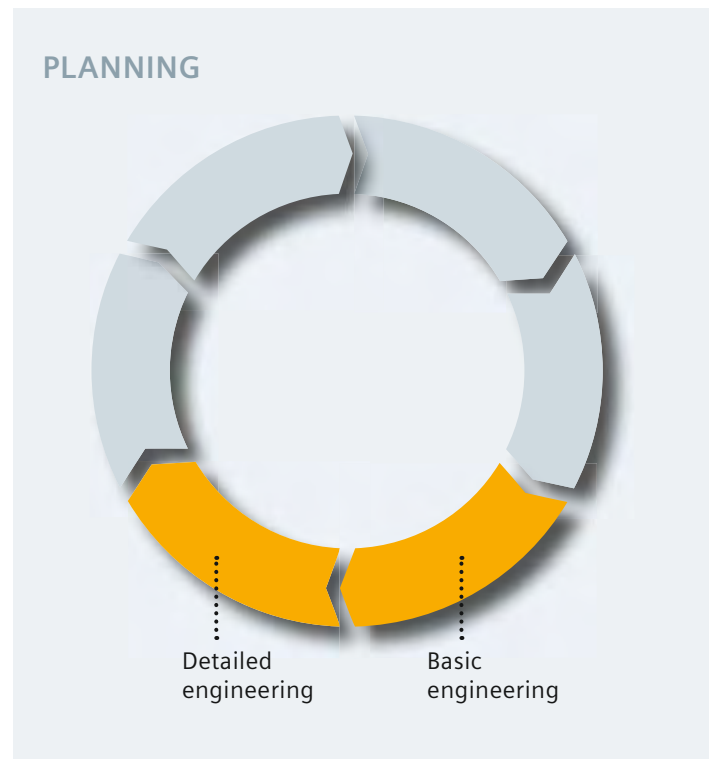

Planning example: Energy storage units tap saving potential

The storage of braking energy by stationary energy storage units enables the primary energy demand of a rail vehicle to be reduced by as much as 30%.

30%

Reality | 1

The energy efficiency of railway electrification is mainly measured in terms of its energy saving potential. Siemens possesses a path-breaking range of products with the latest technologies for high environment-compatibility and greater economic efficiency. Once integrated in your system, our products enrich the ecological attribute of your electrification solution.

Efficiency you can grasp

With braking energy into the future? Modern technologies in the area of traction engineering considerably improve the drive system of rail vehicles and thus reduce energy consumption enormously. The energy storage units of the Sitras family are the heart of your custom-made electrification system. They save energy in daily use by storing the braking energy that is released and thus make a decisive contribution to the reduction of lifecycle costs as well.

Energy-efficient systems:

Three products for tailor-made solutions

Siemens can offer you three components that ensure the energy efficiency of your system in different ways. When performing the preparatory calculations, our engineers consult with you to determine the best possible energy storage product for your individual mass transit system.

Sitras TCI inverter:

More current for stops along the line

The Sitras TCI inverter makes it possible to transfer the braking energy into the higher-level medium-voltage power system. Large distances can be overcome easily so that even very remote consumers can be supplied with the necessary power. Since the medium-voltage power system is capable of absorbing the recovered brake energy at any

time, the design of the braking resistors on the vehicles is also optimized – which means weight savings. Substations can also be retrofitted with a standby Sitras TCI inverter to make them capable of handling recovered energy. The robust and reliable thyristor technology ensures optimal energy transmission. Moreover, parameterization, control and diagnosis can be carried out by means of a standardized communication interface independent of the location.



Sitras SES based on Sitras ESM 125:

Energy saving potential you can rely on

The Sitras SES stationary energy storage unit creates optimum preconditions for energy recovery in mass transit systems. The Sitras SES can store and emit energy extremely quickly, enabling an exchange of energy with the vehicles. Besides that, the primary energy requirement is reduced by up to 30% without any influence on transport capacity or punctuality.

The core of Sitras SES: the new, compact Sitras ESM 125 energy storage module. The module's additional enclosure corresponds to a degree of protection of IP65 and contains additional fillers to provide extra operational safety. Tested by TÜV Süd according to BOSTrab.

Sitras SES works in two modes:

- Energy saving mode: braking energy is absorbed, stored and later released for acceleration purposes.
- Voltage stabilization mode: the degree of charging is kept constantly high and energy is only released when the system voltage falls below a predefined limit.

Sitras MES/HES based on Sitras ESM 125:

Saving energy simply by driving

The Sitras MES and Sitras HES mobile energy storage units add a mobility factor to the proven technology of braking energy recovery. Electric and diesel-electric vehicles can be retrofitted with the systems.

The Sitras HES hybrid concept even goes one step further by combining the advantages of storage technology with the possibilities of a traction battery. Mass transit systems without an overhead contact line are thus possible and not only reduce energy costs, energy consumption and CO₂ emissions but can also be integrated into every urban environment almost without being noticed. These new variants also include the new Sitras ESM 125 energy storage module.

Continuous optimization:

Lifecycle under the microscope

Our work is by no means over when your mass transit project has been implemented. After commissioning, we continue to provide support for your system, subjecting the measured data and configurations to ongoing checks. Rationally based improvements can therefore be carried out at any time, assuring you that your mass transit system is operating efficiently.

IMPLEMENTATION

Installation and commissioning

Manufacturing and delivery

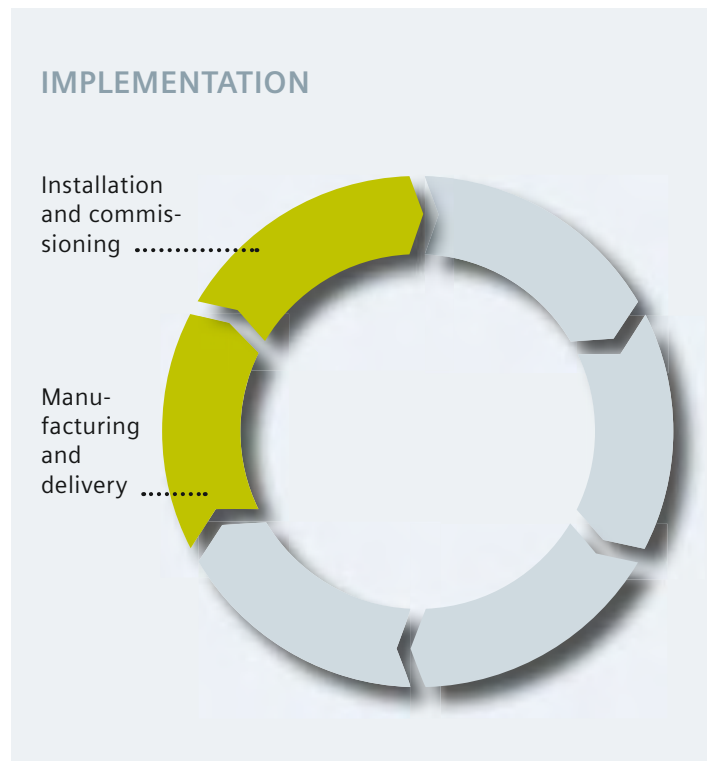

Saving energy globally: If all the DC railway systems in the world used energy storage systems or inverters, CO₂ emissions could theoretically be reduced by as much as 11.6 million tonnes.

11.6
million tonnes

This figure roughly corresponds to the CO₂ emissions of a central European city with one million people.

Reality12

In use worldwide

The energy efficiency of railway electrification is mainly measured in terms of its energy saving potential. Siemens possesses a path-breaking range of products with the latest technologies for high environment-compatibility and greater economic efficiency. Once integrated in your system, our products enrich the ecological attribute of your electrification solution.





Kölner Verkehrs-Betriebe AG
Cologne, Germany

From April 2001 to January 2003, Kölner Verkehrs-Betriebe tested a prototype of a Sitras SES stationary energy storage unit with double-layer capacitor technology. The result convinced the customer's experts. Only one year later, four energy storage systems were purchased and put into operation.

Scope of services: Four turnkey systems, including engineering, manufacture, installation and commissioning

Commissioned: 2003, 2004, 2006

Main components: Double-layer capacitor bank, converter, control system, connection unit

Supply voltage: 750 V

Modes: Energy saving, voltage stabilization



Metro de Madrid SA
Madrid, Spain

In Madrid, two Sitras SES stationary energy storage units with double-layer capacitor technology ensure stable voltage conditions along railway routes. Simultaneous acceleration of several trains at a time is no longer a problem in the Spanish capital.

Scope of services: Two turnkey systems, including engineering, manufacture, installation and commissioning

Commissioned: 2003

Main components: Double-layer capacitor bank, converter, control system, connection unit

Supply voltage: 750 V

Mode: Voltage stabilization



Beijing Metro
Beijing, China

Beijing, the host city of the Olympics, has been using the energy saving power and stabilizing capacity of four Sitras SES stationary energy storage units since February 2007. The stationary energy storage units are being used at a total of four installations.

Scope of services: Four turnkey systems, including engineering, manufacture, installation and commissioning

Commissioned: 2007

Main components: Double-layer capacitor bank, converter, control system, connection unit

Supply voltage: 750 V

Mode: Energy saving



**VAG Verkehrs-
Aktiengesellschaft**
Nuremberg/Fürth, Germany

Since 2007 VAG in Nuremberg has been able to rely on the energy saving potential and stabilizing capability of Sitras SES stationary energy storage units.

RET
Rotterdam, Netherlands

Since 2010, a Sitras SES stationary energy storage unit has been making sure that braking energy is absorbed, stored and released for acceleration purposes.

Toronto Transit Commission
Toronto, Canada

The Toronto Transit Commission has placed its trust in a Sitras SES stationary energy storage unit to reduce the primary energy demand of its vehicles and increase the reliability of its system.

Scope of services: Four turnkey systems including engineering, manufacture, installation and commissioning

Commissioned: 2007, 2011

Main components: Double-layer capacitor bank, converter, control system, connection unit

Supply voltage: 750 V

Mode: Energy saving

Scope of services: Turnkey system including engineering, manufacture, installation and commissioning

Commissioned: 2010

Main components: Double-layer capacitor bank, converter, control system, connection unit

Supply voltage: 600 V

Mode: Energy saving

Scope of services: Turnkey system including engineering, manufacture, installation and commissioning

Commissioned: 2011

Main components: Double-layer capacitor bank, converter, control system, connection unit

Supply voltage: 600 V

Mode: Energy saving



**Bayerische Zugspitzbahn
Bergbahn AG
Zugspitze, Germany**

The installed Sitras TCI inverter has transformed the braking applications for vehicles operating on Germany's highest mountain. Part of the braking energy created by vehicles travelling downhill used to be dissipated at the brake resistor but can now be fed into the customer's own medium-voltage ring.

Scope of services: Turnkey system, including engineering, manufacture, installation and commissioning

Commissioned: 2007

Main components: B6 thyristor bridge, autotransformer, control electronics

Supply voltage: 1,500 V

Mode: Energy recovery for optimized power distribution



**Metro Transportes do Sul S.A.
(MTS)
Lisbon, Portugal**

This hybrid energy storage system has been in operation for passenger services since 2008. And it has proved a great success – the vehicle is able to run without an overhead contact line on gradients of up to 2.6% and saves energy.

Scope of services: Engineering, manufacture, installation and commissioning

Commissioned: 2008

Main components: Hybrid energy storage system – consisting of a mobile energy storage unit and traction battery

Supply voltage: 750 V

Mode: Operation without overhead contact line



**Innsbrucker Verkehrsbetriebe
und Stubaitalbahnen GmbH
Innsbruck, Austria**

Innsbrucker Verkehrsbetriebe has been benefitting from the energy saving potential provided by a mobile energy storage unit since 2011.

Scope of services: Vehicle retrofitting: energy storage unit, modification of vehicle converter and control system

Commissioned: 2011

Main components: Mobile energy storage unit, vehicle converter

Supply voltage: 600 V

Mode: Energy saving

Siemens AG
Industry Sector
Mobility Division
Mozartstrasse 33b
91052 Erlangen
Germany

© Siemens AG 2011

Printed in Germany
PUB 26/35957 313687 PA 08110.5
Dispo No. 21711 K No. 7613
Order No. A19100-V300-B711-7600

The information in this document contains general descriptions of the technical options available, which do not always have to be present in individual cases. The required features should therefore be specified in each individual case at the time of closing the contract.

www.siemens.com



SIEMENS

[siemens.com/rail-electrification](https://www.siemens.com/rail-electrification)

Mass transit solutions for operation
without overhead contact line.

Sustainable. Energy-efficient. Trendsetting.

Answers for infrastructure and cities.

An aerial photograph of a city, likely Philadelphia, showing a wide river (the Schuylkill River) with a large stone arch bridge (the University City Bridge). The city skyline is visible in the background under a clear blue sky. The foreground shows various buildings and infrastructure.

Demographics. The composition of the world's population is undergoing a process of change. It is particularly in industrial states that the ratio between generations is becoming imbalanced. The population is on the increase and aging – and there is a rising need for innovative mobility solutions.

Sustainable.
Mobility with a vision.

An aerial photograph of a city skyline, likely London, showing a mix of modern skyscrapers and older buildings. A semi-transparent grey box is overlaid on the top left portion of the image, containing text. The sky is blue with light clouds.

Climate change. Worldwide CO₂ emission levels have to be reduced. The transport sector in particular features enormous potential for cutting down on CO₂ emission. Solutions are to be found in a detail-focused approach – and in the use of future-proof technologies.

Urbanization. Megacities are growing, almost unlimitedly. Today, more than half the world's population lives in cities. Against this background, it is a question of harmonizing individual mobility and energy savings – a challenge for mass transit in particular.

A close-up aerial view of a city street, showing a red double-decker bus and a white van. A semi-transparent grey box is overlaid on the top portion of the image, containing text. The background shows the tops of buildings and a road.

Focus on the city. More than ever before, the quality of life and competitiveness depend on cost-effective, future-oriented transportation systems. The requirements facing mass transit systems are increasing – especially in metropolises and conurbations. What is in demand is an optimum combination of speed, capacity, attractiveness and environmental compatibility. This is because cities need air to breathe. That is why new technologies should be capable of becoming easily integrated into existing infrastructures. It is only in this way that town planners, infrastructure decision-makers and mass transit operators can secure their investments sustainably.

Energy-efficient. Technology with potential.

Less energy consumption. Less CO₂ emission. More efficiency. These are the objectives of local authorities and cities. Objectives which can only be achieved by using innovative mobility technologies – sustainable technologies which Siemens is focusing on.



Complete mobility.

With more than 160 years of experience in passenger transportation, Siemens knows the requirements encountered in the urban environment and offers conurbations a full-scale portfolio of future-proof technologies. With this in mind, we are applying our “Complete mobility” approach to implement solutions for sustainable city and transportation development. Environmental and climate protection are considered just like aspects of cost-effectiveness and efficiency. One innovative example is the Sierras® HES hybrid energy storage system.

Cost-effective energy storage systems.

Sierras HES opens up entirely new perspectives for cities – thanks to its intelligent storage and usage of braking energy. Vehicles featuring this technology consume up to 30 % less energy per year and emit up to 80 tons of CO₂ less. What is more, the traction power supply becomes more stable since the voltage drop along the overhead contact line is reduced, particularly in high-peak operating periods. Sierras HES enables trams to run without overhead contact lines for distances of up to 2,500 m. Whether in

tunnels, on bridges or at major intersections, the system is particularly suitable for complex structural locations which make it difficult to install overhead contact line. Moreover, routes without overhead contact line mean less installation work, and that, in turn, entails lower electrification costs for operators and more flexible possibilities for town planning. The special feature of our system is that it is designed to function on narrow-gauge railways too. A system which both cuts energy consumption and adds to the attractiveness of the cityscape.

Effective combination.

Sitras HES consists of two basic components: the Sitras MES mobile energy storage unit and a traction battery. In addition to storing braking energy, Sitras HES uses this storage function to provide a new operating mode – operation without overhead contact line. Control in this energy-efficient operating mode can be adjusted to such a precise degree that the optimum solution required by the customer can be achieved – energy savings

and peak power reduction. If more energy is generated during braking than can be stored, this energy is fed back into the contact line. The hybrid concept can be integrated into new rolling stock and existing vehicles can be retrofitted with this system too. In this way, not only energy consumption, energy costs and CO₂ emission can be reduced, but the cityscape can also be visibly preserved and enhanced.

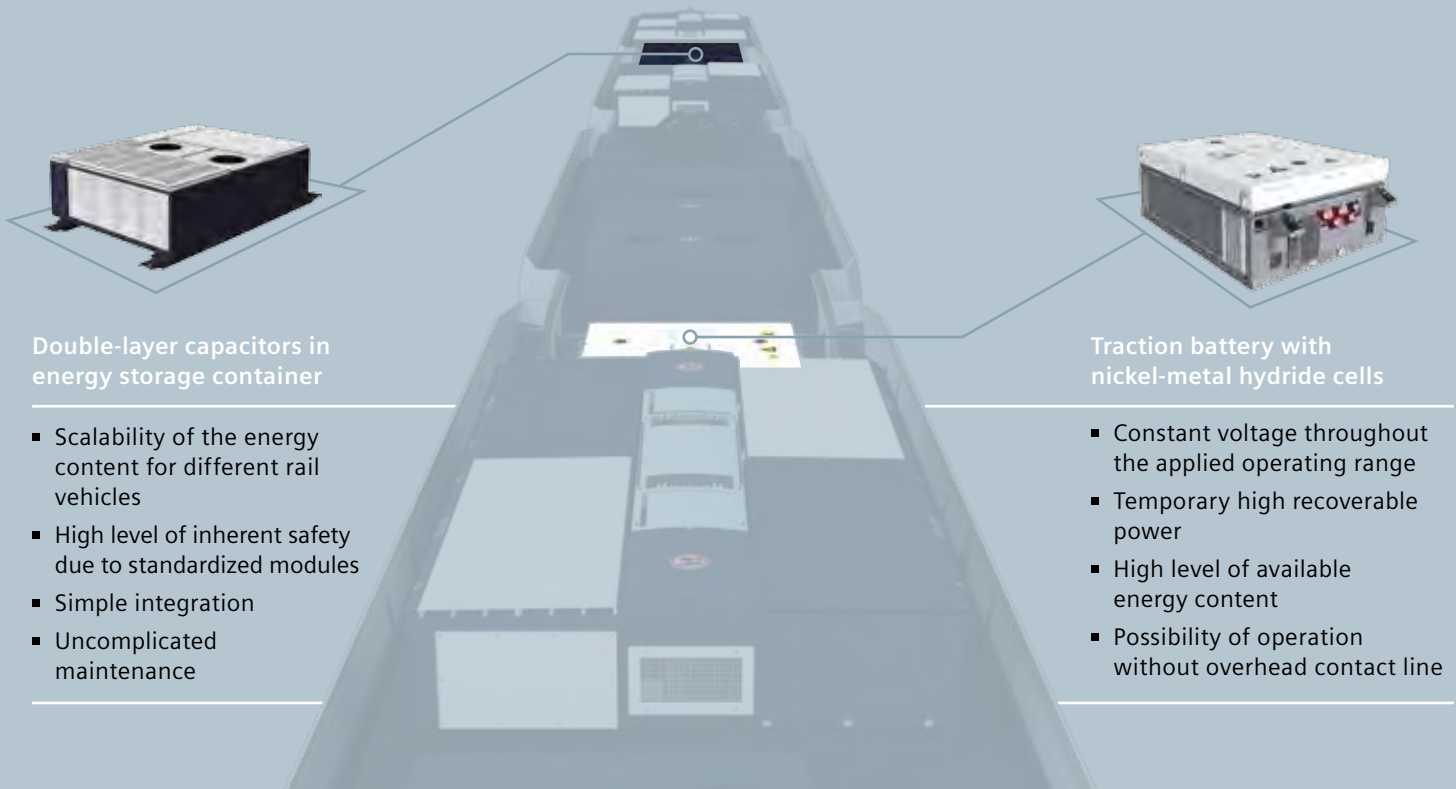

Charging of the energy storage system by braking during operation



Charging of the energy storage system on routes with overhead contact line and at charging stations or stops within just a few seconds by local charging units at stations or stops

Trendsetting.

Performance with a future.

Storage system for usage of braking energy. Worldwide CO₂ savings of up to 4.6 million tons. So that both human beings and the climate can breathe. Modular retrofitting and platform concepts ensure that these perspectives become reality.

Convincing hybrid concept.

Energy storage systems are future-proof – for both the climate and the operators. Siemens has therefore developed a retrofitting option which enables the energy storage unit to be subsequently connected outside the traction converter too. The Sitras MES and Sitras HES energy storage systems are optional components of Siemens' new Avenio tram platform. An efficient overall solution which has

already proved itself in practice. In Portugal, south of Lisbon, Siemens' Sitras HES hybrid energy storage system has been in passenger operation since 2008. With success too, since the trams run without overhead contact line on gradients of up to 2.6 % and save energy. Environmentally friendly and cost-effective at the same time, this system proves how smoothly both operating modes function.

Overview of benefits.

Cost-effective and environmentally friendly

- Reduction in energy demand by up to 30 %
- Optimization of life cycle costs with 99.8 % availability
- Lower cost-intensive peak power demand
- Larger intervals between stops and substations
- Reduction in CO₂ emission by up to 80 tons per vehicle per year

Powerful and safe

- Increase of performance by reducing the voltage drop within the traction power supply
- Scalable energy content
- Simple retrofittability
- Equipment for Avenio
- Tested by TÜV Süd (German Technical Supervisory Association) in line with BOSTrab (German Construction and Operating Code for Light Rail)





Future perspectives. Whether on roads, on rail or in the air – in future, transportation has to be controlled and networked even more intelligently. It is only in this way that the existing infrastructure can be used efficiently and, at the same time, our climate protected. With this in mind, Siemens offers a wide range of possibilities – and is continuously developing new systems, products and technologies which set new criteria in terms of climate neutrality. Thanks to their scalable energy content, our energy storage systems can be used not only for trams but also in other rolling stock. We benefit from our many years of experience and our technological know-how. What is the reason for our strength? We offer not only mobility solutions from a single source but also an incomparably full-scale portfolio.

Put your future on the right tracks and contact us!



Published by and copyright © 2012:

Siemens AG
Infrastructure & Cities Sector
Smart Grid Division
Humboldtstrasse 59
90459 Nuremberg, Germany

Siemens AG
Infrastructure & Cities Sector
Smart Grid Division
Rail Electrification
Mozartstrasse 33 b
91052 Erlangen, Germany

electrification.mobility@siemens.com
www.siemens.com/rail-electrification

Order no.: IC1000-G230-A103-X-4A00
Printed in Germany | AL=N ECCN=N
Dispo 6403 | c4bs-Nr. 776
HL 12077170 | GB | WS | 08120.5

Sitras® is registered trademark of Siemens AG.

All rights reserved.

Trademarks mentioned in this document are the property of Siemens AG, its affiliates, or their respective owners.

The information in this document contains general descriptions of the technical options available, which do not always have to be present in individual cases. The required features should therefore be specified in each individual case at the time of closing the contract.

Edinburgh Tram Network

Wire-Free Traction System Technology Review

Doc. Ref: ULE90130-SW-SW-REP-00107 V3



*Parsons Brinckerhoff Ltd
Edinburgh Tram Network
SDS Provider
16 Abercromby Place
Edinburgh, EH3 6LB*

*Telephone: 44(0) 131 272 3318
Facsimile: 44(0) 131 272 3302
Email: edinburghtram@pbworld.com*

9th March 2006

AUTHORISATION PAGE

Title: Non-Functional Requirements Specification				
Approvals	Name	Position	Signed	Date
Author	J Baggs	Technical Director		
Reviewer	C Mason	Design Manager		
Project Manager	P McCauley	Project Manager		

Description

Ver No	Date	Description	Prepared By
1	19 Dec 05	Formal Issue to tie	J Baggs
2	17 Jan 06	Internal and External Comments	J Baggs
3	9 Mar 06	Formal Issue to tie	J Baggs

Distribution

Ver No	Date	Name	Role	Company
1	19 Dec 05	Willie Fraser	Contract Representative	tie
2	17 Jan 06	Internal and External Comments	Reviewer	PB
3	9 Mar 06	Willie Fraser	Contract Representative	tie

EXECUTIVE SUMMARY

As part of a series of technology reviews required to be carried out under the SDS contract for the Edinburgh Tram Network, Parsons Brinckerhoff (PB) have conducted an investigation into the options for a wire-free traction system, in order to see if there is a viable alternative to the use of a conventional overhead power supply system either throughout the system or just within the World Heritage Site. The need to look carefully at this subject arises from the aspiration to avoid the use of overhead equipment particularly in the most visually sensitive areas if possible. A survey and assessment of the full range of available options has been undertaken, in light of the specific operational requirements of the Edinburgh Tram Network and the provision required for the future construction of Line 3, with a view to seeing whether it will be possible to provide a wire-free system by using any of the means currently available.

To provide a complete and robust review of the possibilities the available options have been examined and evaluated using a series of standard criteria, namely: weight, re-fuelling, noise and vibration, vehicle life, vehicle availability and reliability, vehicle compatibility with infrastructure, passenger capacity impact, performance and capital and operating cost. The options fall basically into two groups:

- *On-tram solutions* - Involving generating and/or storing traction energy on the trams to allow them to operate independently of an overhead supply.
- *Infrastructure solutions* - Supplying power to the tram from the infrastructure but without the use of an overhead supply.

The on-tram solutions examined were traction batteries, flywheels, fuel cells and super capacitors, together with an on-board prime mover, with or without energy storage (diesel or diesel hybrid). In the case of the on-board prime movers, alternative fuels such as liquid petroleum gas were not pursued in detail, as they are merely variations on the same basic theme.

Within the infrastructure solutions the number of available options is much lower and the review therefore considered only two main alternatives: the French APS or 'ground power' conductor rail system as used in Bordeaux, and a modern equivalent of cable haulage

Each of the options was considered in the context of its current state of development and availability to suit the timescale of the project. Its suitability either for the operation of the central part of the Edinburgh network or for the complete network was also a major factor. Capital and operating costs were considered mainly in comparative terms since detailed data is not generally available for the novel solutions concerned.

The modern low-floor tram is a well-developed product that is available from a limited number of major international suppliers. The Edinburgh system for which Bills have been deposited in the Scottish Parliament is based around the use of technology of this general type. The technology review therefore took standard low-floor tram technology as a starting point in examining the options for powering it.

None of the developed or potentially available on-vehicle energy storage systems would have the operating range and endurance to meet the requirement for wire-free operation within the World Heritage Site, although all of them would permit some movement over relatively short distances and with varying operational restrictions.

Each of the options would add significantly to the cost and weight of the vehicle. In the case of the battery option the passenger payload would have to be reduced to compensate, as it might to a lesser extent for the other options.

Wire-Free Traction System Technology Review

Super capacitors have been developed primarily to improve energy efficiency and might be worth pursuing for that reason alone, although they could also provide some very limited wire-free capability.

The wholly diesel-powered option which would involve adding a prime mover to the tram is incompatible with the basic system concept, in terms of its performance, availability, reliability and other factors.

The hybrid diesel-electric option, capable of operating from an overhead supply outside the city centre and from the engine or from batteries charged by the engine within the World Heritage Site, would offer greater operational flexibility but would not meet the system performance requirements when away from the overhead. There would be an increase in vehicle cost and weight, combined with a reduction in passenger payload of about 10% or more and a reduction of approximately 50% in tram performance.

The French APS ground power system is free from the limitations of distance and range associated with most of the alternatives and it also avoids some of the weight associated with the on-tram alternatives. However, it does impose certain operational restrictions, primarily in terms of maximum speed.

APS has not yet achieved an acceptable level of reliability on a network wide basis, although the indications are that it may do so in the future. The greatest difficulties involved with its possible use in Edinburgh relate to the fact that it has only been applied in one city so far, Bordeaux, under climatic and regulatory conditions that are very different from those applying in the UK. It is most unlikely to be available within the required timescale, if at all. Further factors which operate against it are the difficulty that the power system and the trams that run on it would only be available from a single supplier, which would rule out effective competition in this key area, and the significant visual impact of the power supply rail on the road surface and paving.

Cable haulage although widely used for specific applications such as segregated airport shuttles would not meet the operational requirements of a modern urban tramway and would be expensive to implement and maintain. The regulatory and approvals issues that it would raise would be considerable and again it could not be available within the required timescale even if the basic objections to it could be overcome.

Of the options considered only the APS system comes close to having a network-wide capability. Its introduction in Edinburgh would, however, raise many issues including legal and regulatory ones. These problems would be more severe because at the present time it is used in only one other city, has still to achieve the necessary level of reliability and has not been subjected to the anything like the climatic conditions found in Edinburgh.

None of the on-vehicle options comes close to meeting the operational requirements within the World Heritage Site although the use of super capacitors would probably be worth considering for reasons primarily of energy efficiency. This approach might enable some limited wire-free operation, for example through little used emergency crossovers, but this would essentially be a bonus rather than the main reason for adopting it.

In conclusion, at the present time there does not appear to be a feasible alternative to the system-wide use of an overhead contact system without importing a significant degree of risk. For that reason work should proceed on the basis that the whole of the system should be wired, at least initially. In parallel with that, the tram procurement process can take into account the possible wider benefits from the use of super capacitors and test the market to see what is on offer at the time, at what price and with what guaranteed level of performance. It might then prove possible, for example to leave certain emergency crossovers unwired and to use the energy storage system when operating through them.

CONTENTS

EXECUTIVE SUMMARY	3
1 BACKGROUND	6
1.1 Purpose of the Project Management Plan	6
2 INTRODUCTION	7
3 THE MAIN OPTIONS	9
4 ON TRAM OPTIONS	10
4.1 Batteries	10
4.2 Flywheels	12
4.3 Super Capacitors	14
4.4 Fuel Cells	16
4.5 Diesel Powered Trams	16
4.6 A Diesel Hybrid Vehicle	17
5 OFF-TRAM OPTIONS	20
5.1 Ground Level Power Supply	20
5.2 Other Options	24
5.3 Roles and Responsibilities	25
5.4 Communication and Reporting Lines	26
6 EVALUATION	27
6.1 Strengths and Weaknesses	27
6.2 Assessment	29
7 SUMMARY AND CONCLUSIONS	31
8 APPENDIX A – REPORT ON THE BORDEAUX APS SYSTEM	33

1 BACKGROUND

1.1 Purpose of the Project Management Plan

PB Limited is required to carry out a review of a number of areas of technology at an early stage as an essential part of the responsibility for the development of the system design under the SDS contract. A number of subjects for Technology Review were identified in the SDS scope of services, Section 2.5. In addition the need to examine alternative technologies such as wire-free current collection for traction purposes were identified elsewhere in the brief e.g. 2.4.2.3.

This Technology Review is concerned with the implications of a possible wire-free current collection system. In this context 'wire-free' means a traction system that does not rely upon an overhead contact wire for all or part of the route.

New tram systems have been introduced in many countries in recent years. While some of those within the British Isles show clear evidence of a 'learning curve' so far as the design of overhead equipment is concerned, there are many international examples of systems that are both well designed and in sympathy with their surroundings. Closer to home the new tramway in Dublin is a good example of how well designed overhead can improve the quality of a system.

However, no matter how well designed any overhead system is, it will still be visible and will cause a degree of concern, particularly at the planning stage. The City of Edinburgh's Draft Design Manual of July 2005, refers to the need for a wire-free traction system to be seriously examined as an alternative to a conventional overhead power supply. It refers in particular in Section 4.43 and elsewhere to the aspiration for a 'wire-free' power system and the reasons for this.

In addition, the promoter, City of Edinburgh Council, has received representations from a number of interest groups, particularly those concerned with heritage and environmental issues, on the desirability of avoiding the use of overhead line equipment within the World Heritage Site and more widely if at all possible.

This review addresses the issues raised in the Draft Design Manual and by the other interest groups. It examines the options to the use of conventional overhead equipment and considers the strengths and weaknesses of each and their suitability for use on the Edinburgh Tram Network, either solely in the most sensitive areas or more widely. Although it is assumed that any overhead equipment used on the Edinburgh network will be designed to the highest aesthetic standards, such considerations do not form part of this review which is confined to the consideration of the alternatives to such a system.

2 INTRODUCTION

Before evaluating the various options to the use of overhead equipment it is necessary to identify them and establish which of the options merit more detailed analysis. The Draft Design Manual identifies the need to consider the options to the use of an overhead contact system in the most visually sensitive parts of the system and possibly more widely.

It is clear that a number of options have been examined in the course of developing the project and prior to the involvement of PB. These are outlined in the Witness Statement of Scott McIntosh of Mott MacDonald of 31st May 2005 and the report by Roger Jones of **tie** to the Murrayfield Community Council of 3rd June 2005.

Both these reports examine a number of options and both, to some extent, also include a comparison of the alternatives with 'best practice' in respect of the design and installation of overhead power equipment.

This review focuses entirely on the potential options to an overhead power system and does not consider the design of the overhead system itself other than in respect of the possible interfaces between the two power supply systems at transfer points.

Two alternative approaches to the use of a wire-free system are considered. These are:

- For the whole of lines 1 and 2, and,
- Only for the length of route through the central part of the World Heritage Site (from Shandwick Place to Picardy Place, a distance of about 1.8 to 2.0km).

All the central section referred to above would be used by trams on both Line 1 and Line 2, while about 1.3km of it would also be shared with trams on Line 3. The eventual combined tram frequency on the common section could be up to about 24 trams per hour and per direction. There are four tramstops on the section of route within the World Heritage Site and the average distance between stops is therefore about 600 metres. The section of route is generally flat and straight or curves only gently apart from the route into and through St Andrew Square which has curves of approximately 25 metre radius on the tracks connecting to it in each direction and gradients of about 7 or 8%. This section is likely to be the most demanding for any system of wire-free traction.

The various options are assessed in terms of their implications and suitability for the two main requirements outlined above: either for the whole of the route or merely for the section within the World Heritage Site.

The principal features of each option are discussed and their characteristics established on a common basis. In order to make a comparative assessment the implications of each are reviewed under the following headings in accordance with the SDS Technology Review Scoping Report of November 2005:

- Functionality – the ability to deliver against the requirements specification
- Availability – both for the initial installation and ongoing operation
- Impacts – including construction and visual ones
- Safety
- Hazards
- Costs – both initially and on an ongoing basis
- Risk profile – in the first instance and subsequently

- Reliability, Availability, Maintainability and Safety

3 THE MAIN OPTIONS

The main alternatives to the use of an overhead power supply system fall into two main groups:

- **On-tram** - power sources that could be installed on a tram to enable it to operate independently of an overhead power supply, either for a limited time and distance (for example through the World Heritage Site) or on a continuous basis for the whole of a typical duty cycle.
- **Off-tram** - power sources, other than overhead, that are part of the infrastructure and independent of the tram. These must be capable of supplying power, or traction in some other form, to the tram either for a limited distance (for example through the World Heritage Site) or throughout the network.

Each of these categories has been examined in turn to identify systems that already make use of relevant wire-free technology which might be applicable to Edinburgh. It is apparent that the number of potentially viable options in each group is in fact quite limited for an intensive urban operation. Although there has been substantial growth in the number of tramway systems worldwide in the past few decades and significant extensions to many of the longer-established ones, nearly all of these use a conventional overhead power supply. A small but increasing number do use dual-voltage traction equipment to allow trams to inter-work over local electrified railway lines, but in only a few cases are power sources other than an overhead contact wire involved.

Although a great many different traction arrangements have probably been put forward for light rail systems at one time or another, we have concluded that the options should be reduced to the main generic types and that there would be little benefit in examining the more marginal ones or ideas that are merely variations on the main themes. On this basis the main options for wire-free traction have been identified as:

- **On-tram** power sources.
 - Batteries
 - Flywheels and traction capacitors
 - Fuel cells
 - Diesel either as the main or as an auxiliary power source (including alternative fuel sources such as LPG to achieve the same purpose)
- **Off-tram** infrastructure alternatives
 - Ground level surface contact (Alimentation par Sol - APS)
 - Cable traction (Soule or equivalent)

All other realistic alternatives should be covered to a greater or lesser extent by these options.

Each option has been analysed in turn on the basis of either published data, input from potential suppliers or a review of existing comparable systems. In each case we have considered its suitability for use on the Edinburgh Tram Network together with the type and level of risk that it would import to the scheme. None of the options is likely to be entirely risk free and the risks that have been considered include regulatory approvals, construction, cost, programme, operational performance and reliability factors. We have also considered whether the evaluation would differ if an option were considered for use throughout the network as opposed to only on the most sensitive parts of the route.

Unless they are to be used continuously throughout the tram network each of the options would impose some time delay during the changeover from one mode of operation to another and

interlocks would have to be put in place to ensure that a tram could not, for example, move off with its pantograph raised or its shoe gear 'live' when it was in an alternative mode of current collection.

4 ON TRAM OPTIONS

4.1 Batteries

There have been considerable developments in the field of batteries for traction purposes in recent decades. These developments have had the effect of gradually improving the life and performance of the batteries, while at the same time improvements have been made to the control equipment and motors used with them. This has resulted in more economical packages with a greater operating range being available but it has not yet provided the major breakthrough that has been promised for several decades. At the present time batteries on their own are still some way from being able to meet anything like a typical urban transport duty cycle – particularly for a vehicle with the size, weight and passenger payload of a tram.

Batteries are by their nature bulky and of limited endurance. Thus most of the commercial applications are for vehicles which are required to operate only for limited periods with sufficient time in between periods of use for re-charging (such as at airports and for certain sorts of deliveries). In the passenger transport field traction batteries tend to be used mainly for vehicles like trolleybuses to enable them to manoeuvre for a limited time off the overhead wire. This is typically to deal with an emergency or to allow overhead equipment to be simplified in a depot. The batteries are re-charged when they are operating normally from the overhead.

This approach is rare on tram systems but the new Bordeaux system uses traction batteries to supplement the APS ground power system, to allow the tram to keep moving in the case of a local interruption in the supply, and the system under construction in Nice will use batteries on two relatively short sections which will not be equipped with overhead. The Caen hybrid 'guided trolleybus' system which has been in operation for some time also uses traction batteries but only when travelling out of service between the depot and the nearest part of the route.

A further variant is provided by some trolleybus systems on which the traction battery is re-charged by an auxiliary engine and generator when the bus is operating away from the overhead line. This enables the vehicle to operate independently without having to have a fully rated automotive engine to drive it and permits it to operate for a substantial period without the risk of it becoming stranded due to flat batteries, for example for a route extension. Hybrid vehicles of this type are in a distinct category and are considered in more detail in Section 4.5 below.

For rail vehicles that are to rely entirely or mainly on battery power the implications will vary depending on the approach which is employed. For an urban tramway such as Edinburgh the use of a vehicle whose batteries are only re-charged 'out of hours' or when it is standing at the terminus is precluded by the stop spacing, route length, gradient profile and duty cycle. This is because the demand on the battery when running over a route of this type would be such that an uneconomically large battery would be required and the time to re-charge it at the end of each journey would be excessive. Although the experimental battery railcar unit which operated between Aberdeen and Ballater some years ago, had its batteries recharged at the terminus in this way during a significant layover, this approach would not be suitable for an urban tramway.

A pure battery tram would not therefore be a feasible proposition and an overhead/battery powered tram would have to spend most of its time operating from the overhead and only rely on its battery for a limited period of time and part of the route.

The trams in Bordeaux which entered service about two years ago have traction batteries which enable them to operate independently of the infrastructure. However, they are only designed to use their batteries in the event of the failure of a short section of the APS ground power system.

Wire-Free Traction System Technology Review

The batteries for this very limited duty add about 0.85 tonnes (2%) to the weight of the tram. We understand that they are currently being replaced after two years service but this may be untypical because of the teething problems with the APS system.

The Nice trams, which will have to operate over two sections each of just under 0.5km at a speed of about 40km/h, and carry about an extra 3 tonnes of batteries and associated equipment (about 8.5%) to power them. They will use Saft NiMH (Nickel-metal hydride) batteries and will incorporate a battery cooling system. At the present time the Nice trams have still to enter service so there is no experience of their performance.

While a reduction in speed should reduce the demand on the battery and increase the range of the vehicle, anything other than straight level track would have the opposite effect. It is interesting that in the case of the Nice tram, even with a relatively large traction battery and the advanced technology being used, the length of time that the car is able to operate away from the overhead line, will be strictly limited.

Both Bordeaux and Nice either use or will use the Alstom Citadis tram so they may be considered to be representative of the performance and battery requirements for other similar trams in current production.

The only practical approach for a battery/overhead tram would be to use the battery only for a very limited period, for example to travel through a part of the World Heritage Site, and to operate from an overhead supply for the rest of the time. It appears that the duty cycle in Edinburgh will be approximately four times as demanding as that in Nice before local factors such as the gradients on South St David Street and South St Andrew Street are taken into account. Even a battery of the size proposed for Nice together with a significant limitation on the maximum speed of the tram would therefore only enable a tram to operate in wire-free mode for about a quarter of the distance within the World Heritage Site. There must be some doubt as to whether it would be possible to deliver a practical solution within the constraints of a relatively standard tram, even before issues such as cost and reliability are taken into account.

Taking each of the main factors into account our assessment of this option is as follows:

Weight: The batteries would add about 3 tonnes to the weight of the tram; significantly more if the desire to operate in wire-free mode through the World Heritage Site was to be met. This would be likely to mean that the passenger payload must be reduced to compensate. The cost of having to carry this additional weight around at all times would also have to be taken into account.

Re-fuelling: The combined battery/overhead vehicle would not require re-fuelling, though close attention would have to be paid to the need for frequent re-charging.

Noise and vibration: The battery/overhead vehicle should be no noisier nor vibrate any more than an equivalent conventional overhead electric vehicle.

Vehicle life: The life of a battery/overhead vehicle would not differ significantly from that of a conventional electric vehicle, the batteries would however have a limited life and would have to be replaced on a regular basis.

Vehicle availability and reliability: A battery tram would not have the same high level of availability and reliability as a conventional tram. The additional maintenance tasks and the time required to carry them out would impact on vehicle downtime and it must be assumed that battery and charger problems would arise from time to time either when the cars were in service or being prepared in the depot. With sufficient experience the effect of ageing on the batteries could be offset by replacing them after a shorter life although this would involve spending the equivalent of about 5% of the capital value to the tram every few years. A further factor is that the constant replacement of the traction batteries is not without its own environmental cost. While the details of

this would depend upon the type of battery finally chosen, it is likely that the relatively sophisticated substances involved in its manufacture could be difficult to dispose of.

Vehicle compatibility with infrastructure: A vehicle which made occasional local use of batteries would be broadly compatible with the system infrastructure. Substantial facilities would however have to be provided at the depot for charging, handling maintaining and storing a large number of bulky and heavy batteries.

Passenger capacity: The capacity of a tram equipped to operate for a strictly limited period from a battery would probably be about the same as for a conventional tram, subject to an analysis of such issues as weight distribution and axle loading. A battery/overhead tram able to operate through the World Heritage Site would almost certainly have to sacrifice some part of its passenger payload to remain within acceptable limits on the track, body structure and trucks.

Performance: Vehicle performance will be limited by the capacity of the battery. The most advanced vehicle currently in build, which has still to enter service, appears to have about a quarter of the range that would be required to cover the World Heritage Site in Edinburgh and will be subject to a reduced top speed when in battery mode. Any steps to increase range or performance by measures such as providing charging points at tram stops to top up the battery would introduce significant additional complication and would be likely to adversely affect overall system performance.

Capital and operating costs: The capital and operating costs for an overhead/battery tram would be significantly greater than for a conventional one. The costs would include the higher cost of more complex and non-standard trams together with the additional fixed equipment at the depot, additional spares, handling costs and the regular replacement of the batteries. Reduced vehicle reliability and availability might also necessitate the provision of a marginally larger fleet.

Summary: While at first sight batteries might appear to be an option for a wire-free traction system within the historic city centre of Edinburgh, closer examination indicates that they would not be able to power the section of route within the World Heritage Site, let alone the complete system. A new system that will use traction batteries to a more limited extent will go into public service in the next year or two but its performance and longer term implications are at present unknown. There is no tramway vehicle either in service or under development which meets the operational need within the World Heritage Site.

Adopting traction batteries for any significant part of the route would add substantially to the capital cost of the tramway and introduce significant additional operational performance and reliability risks. Even a limited application would raise the same issues and have a negative effect on ongoing operational and financial performance of the system.

4.2 Flywheels

Flywheels have been used to a limited extent for some years. They were used on a commercial scale in Belgium to power urban buses until about 40 years ago. In that application the electrically powered flywheel was charged by means of static charging points located at bus stops. The aim was to obtain trolleybus performance but without having to provide extensive and unsightly twin-wire overhead equipment. The flywheel units were large, expensive and not very efficient; apparently one of the reasons why the services were discontinued was because the flywheel became discharged during delays in road traffic. In recent times the same principle has been applied in a simpler form to the 'Parry People Mover' system.

Much lighter, smaller and more sophisticated flywheels have since been developed based on high speed centrifuge technology, initially by companies such as Urenco. These have been applied in a static form in traction substations to increase overall energy efficiency by storing regenerated energy produced during the braking of electric trains.

Wire-Free Traction System Technology Review

More recently the technology has been applied on vehicle as well as to substations and during 2005 Alstom have carried out trials on the Rotterdam tram system with a Citadis tram equipped with a roof-mounted high-speed flywheel pack. The use of composite materials has enabled the speed of the flywheel to be increased to between 10,000 and 20,000 rpm and the size and weight to be correspondingly reduced. During recent trials a tram was operated across the Erasmus bridge in Rotterdam for a distance of about 900 metres with an AW3 loading (5 passengers/m²) solely by means of its flywheel pack.

The real purpose of the flywheel development however, as with traction capacitors which are also considered in this section, is to achieve significant improvements in energy efficiency rather than to secure local independence of the overhead. The flywheel permits re-generated energy which cannot be returned to the overhead line because there are no trams available to take advantage of it, to be stored until either the tram that has produced it or another tram is able to make use of it. This enables the proportion of braking energy which is re-used, rather than turned into heat, to be increased significantly.

The work that has been carried out recently by Alstom has been in the nature of a "proof of concept" process and they have still to decide whether to pursue the development of the unit and offer it commercially. There is little doubt that from an energy efficiency point of view the trial has been successful but it is likely that further trials will be carried out before a decision is made on whether to offer it as an option. The view of many in the industry is that energy storage using flywheels is a valuable concept but that it is better carried out at the substations than on the vehicles. At the present time there is very little detailed information available on vehicle flywheels because the product is not yet being pursued commercially.

Although the capital cost of the equipment is unknown, a flywheel equipped tram would clearly be more expensive to buy than a conventional one, but the additional weight should be more than offset by the increased energy efficiency from the use of the flywheel. The unit life, operating and maintenance costs are unknown. Of these items it is medium and long-term maintenance which raises the most questions. The unit is required to operate at very high speeds and contains elements that are safety-critical. It can therefore be assumed that maintenance will have to be carried out off-site by a specialist firm on a unit exchange basis. The implications of this from a cost and availability point of view would require further investigation.

Flywheels on their own do not appear likely to provide the basis for a wire-free traction system either within the historic city centre or more widely. The general view seems to be that if flywheels have a future it will be as a means of increasing overall energy efficiency, rather than to provide independent movement away from an overhead supply. In that case there seems to be a strong argument for locating the flywheel at the substation rather than on the tram.

Weight: 1 tonne (subject to confirmation)

Re-fuelling: There would be no requirement for re-fuelling with flywheels.

Noise and vibration: A modern high speed flywheel should not produce any noticeable noise or vibration (subject to confirmation).

Vehicle life: The installation of a roof-mounted flywheel should not have any effect on the life of the vehicle. The economic life of the flywheel and its maintenance requirements are not known at present.

Vehicle availability and reliability: The provision of a flywheel is not likely to have any adverse effect on vehicle availability. Reliability should be unaffected while the consequences of any unreliability in service (such as through a temporary loss of power supplies or local damage to the overhead) could be reduced as a result of the greater operational flexibility provided by the flywheel.

Vehicle compatibility with infrastructure: The interface between the vehicle and the infrastructure should be largely unaffected except that the interface to the power supply system should be improved as result of the greater energy efficiency of the trams.

Passenger Capacity: The flywheel would have no adverse effect on the capacity of the tram from a space point of view but some passenger payload may have to be sacrificed due to the additional weight. It should have a positive effect on the capacity of the traction power system.

Performance: Flywheels should enhance the normal operation of the system by ensuring that the power system is more robust and that there is some additional operational flexibility due to the limited 'off line' capability. They would not have anything like the independent capability that would be required to provide a wire-free solution within the World Heritage Site.

Capital and operating cost: The capital cost of the trams would be increased by the addition of a flywheel pack as would their maintenance costs. It is not possible to quantify either of these items at the moment although they would probably be significant. If it became a commercially available item the first cost of a flywheel equipped tram would probably depend very much on the manufacturer's commitment to launching it at an attractive price and the likely volume of sales. The price for a small quantity for one system is likely to be unattractive.

Summary: Experience with the use of flywheels on trams is very limited. The need to improve energy efficiency is providing the main impetus to their development and application. At the present time it is not a commercially available item although a significant amount of testing has been done under operational conditions. The ability to operate off-line for a limited period appears to be more of an incidental by-product of the basic development than a primary objective. It is not clear whether all the safety issues associated with installing a high speed unit on the roof of a tram have been satisfactorily addressed.

4.3 Super Capacitors

A traction capacitor is a device which is used to store energy on the tram, typically when braking or when another tram is braking, and then use it to reduce the demand on the power supply system when the tram needs to accelerate. Until recently such devices have been far too heavy and too expensive to be either economically viable or practical for installation on a tram. The steady development of better and cheaper products in the field of power electronics has enabled more suitable capacitors to be produced as was the case some years ago with traction control equipment.

In recent years Bombardier have developed the MITRAC double-layer capacitor unit. Since the middle of 2003 a unit has been on trial on a normal Bombardier service tram in Mannheim. The trial will continue for some time but the unit has already accumulated the equivalent of over a year's running on the most intensive type of urban tramway. The unit is fitted to the tram in normal service and is used to supply one of the two inverter units on the car. The other inverter is fed normally from the line. This arrangement makes it possible to directly compare the power consumption and energy efficiency of the two units, although for a future production application the intention would be to fit a capacitor in conjunction with each traction inverter.

As noted above the capacitor works by storing braking energy, either from the tram to which it is fitted or from other trams which would otherwise have to feed the regenerated energy into their braking resistors.

The analysis that Bombardier have carried out indicates that fitting a fleet of trams with capacitors should save of the order of a further 30% of traction energy on top of the 15% saving typically saved by regeneration. This apparently high figure arises as a result of a combination of eliminating the need to feed braking energy to the resistors and a reduction in the distribution

losses due to the reduction in the proportion of power taken from the substations. The projected performance for such a system in Edinburgh could be analysed by means of a simulation.

The capacitor system is not designed primarily to provide an 'off-line' capability but it does have the ability as a matter of course. Unlike a flywheel the capacitor retains its charge for a substantial period. It gives the tram the ability to run for a limited distance without using the overhead, for example within the depot or through (unwired) crossovers or in the event of a local overhead line fault. The distance possible will depend on the state of charge of the unit at the time and other factors such as passenger load and gradient, but it should be of the order of 0.5km or so.

Capacitors would add about 10 to 15% to the cost of a tram and about 0.9 tonne to the weight. The additional weight is apparently taken into account within the claimed energy saving. The unit has no moving parts, apart from the cooling fans, and a service life in excess of 10 years is claimed. To capture the full benefit it would be necessary to take account of its energy saving ability from the outset and adjust the design of the power system accordingly. Any 'wire-free' operation, which might have the effect of further reducing the cost of the infrastructure, should be regarded as a useful bonus but not the primary reason for its selection.

Weight: The units would add about 0.9 tonnes to the weight of a typical tramcar.

Re-fuelling: There would be no re-fuelling requirement.

Noise and vibration: There should be no noise or vibration.

Vehicle life: The capacitors should have no effect on the life of the vehicle and might have to be replaced once or twice during a 30 year period independently of it.

Vehicle availability and reliability: There should be no effect on vehicle availability. In principle reliability might be improved as result of the greater operational flexibility provided.

Vehicle compatibility with infrastructure: The capacitors should have no negative effects on the system infrastructure, although Electro-Magnetic Compatibility and related issues would have to be examined. Providing that the design of the power supply system was optimised to function with capacitors there should be an overall improvement in compatibility in that area.

Passenger Capacity: The provision of capacitors would have no direct effect on the capacity of the trams or the system, but the passenger payload may have to be reduced marginally to compensate for the additional weight.

Performance: The capacitor, when fully charged, is capable of moving a tram for some distance. The actual performance available at any point in time will depend on its state of charge and such other matters as the size of the auxiliary load on the vehicle that it is required to support in the event of an interruption of the traction power supply.

Capital and operating cost: The capital cost of the trams would be increased but this should be offset to some extent both by the economies that it should be possible to make as a result of the power system and possibly by leaving some little used facilities unwired. The overall system operating cost should be reduced and the maintenance cost of the additional equipment should be negligible although provision would have to be made for replacing the units at, say, ten 10 yearly intervals. Although undoubtedly of benefit to the environment, it is not yet clear whether the savings in energy costs will repay the additional capital cost involved.

Summary: Traction capacitors have been developed as a means of storing braking energy both from the tram on which they are installed and from other trams on the network. The capital and renewal costs associated with them have still to be established, although the initial

indications are encouraging. The equipment has not been developed to provide 'wire-free' operation although it can also have that effect. If the installation of capacitors allows some sections of complex overhead equipment to be omitted, such as emergency crossovers, this may add to the justification. There appears to be no prospect of capacitors permitting wire-free operation over any significant distance within the World Heritage Site at present.

4.4 Fuel Cells

The development of fuel cells for railway applications has been going on for some years although so far without the breakthrough that was originally hoped for. The problems encountered have related to cost, size, power output and the mechanical robustness required for a rail application. In theory the application of fuel cells could combine the advantages of electric traction, including performance and the lack of noise and fumes, with substantial savings in electrical infrastructure.

Fuel cells could be closest in their characteristics to the traction battery option, but without the limitations of range and the need for frequent re-charging that batteries require. However at the present time there is no light rail vehicle or commercial fuel cell system available. An agreement was signed recently in America to develop a 150kW fuel cell drive for a railway vehicle and work is reported to be underway on the development of a 1.2MW locomotive drive.

Due to the fact that these products are still at the development stage detailed information, including cost, weight and performance, is not readily available and so it is not possible to carry out a full assessment. The safety and regulatory implications will be difficult to assess until the details of proven design are available and there is some service experience to support it. The detailed implications for the depot and for handling the substances involved have similarly still to be established.

In addition, the time required to progress them from their present state of development into a commercial product could be considerable. It is most unlikely that this timescale would fit the programme for the implementation of the Edinburgh tram project.

We have concluded that this option should not be taken any further.

4.5 Diesel Powered Trams

This option involves the provision of a diesel engine instead of an electric traction package. The diesel engine would be the only source of power on the tram and would drive the wheels either directly by means of a mechanical transmission or indirectly by means of an hydraulic or electric transmission.

A number of diesel-mechanical vehicles, such as the Regio Sprinter, have been developed in recent years primarily for the operation of local secondary railway lines in Germany although they are also used more widely. They were developed for lightly trafficked lines as a way of facilitating tramway style operation and infrastructure mainly to reduce the cost of operation. They have the ability to operate over sections of street track for short distances although there are few examples of this being done. Such vehicles can offer an economic solution for the operation of lightly used local rail lines and possibly for extending them further into an urban area as a tramway. We have been unable to identify any examples of such vehicles being used to operate an urban network.

The cars that are available are generally built to heavy rail dimensions although they have an intermediate floor height of about 400 to 450mm for loading from low platforms. Since they have been designed to operate over lines built to railway geometry they are not suitable for operation over steep gradients or round sharp curves. The transmission arrangement and the number of powered axles would preclude an application like Edinburgh.

Summary: Diesel trams, although in principle available, do not have the level of performance, the door layout or the internal arrangement necessary for the operation of an urban tram service carrying dense passenger flows at close headways between closely-spaced stops. In addition due to limitations on the number of powered axles and the arrangement of the transmission such vehicles are unsuitable for operation through tight curves and over steep gradients (e.g. down to 25m radius and at between 6 and 10%). The use of such vehicles would raise many issues concerning statutory approvals and regulation.

An all-diesel vehicle has not therefore been examined any further.

4.6 A Diesel Hybrid Vehicle

An alternative to the use of a straight diesel powered tram would be a diesel/electric hybrid vehicle. Under this arrangement an electric tram designed to operate from an overhead power supply would be fitted with an auxiliary diesel power unit and generator. The tram could operate either from an overhead power supply where one is available or from its own auxiliary diesel engine and generator on unwired sections. Another approach would be to fit a traction battery to the car and use a smaller diesel engine, running continuously, to charge the battery. The tram would be powered from the battery on unwired sections.

The same approach could be used with a petrol engine or using alternative fuels such as LPG.

Although the petrol or diesel hybrid approach has been applied to trolleybuses to increase their range and performance when operating away from an overhead supply, it has not so far as we are aware been applied to a tramway.

There are a number of examples of hybrid diesel or LPG and battery powered buses (typically weighing up to about 14 tonnes fully laden), mainly for pilot schemes, but these technologies have still to be applied on a commercial scale to rail vehicles as large and heavy as a tram which can weigh from 60 tonnes to 75 tonnes depending on its length. In addition the safety implications for such an application have still to be considered. In this analysis therefore, a conventional tram modified to operate either from an overhead supply or a diesel engine, has been taken as the basis of comparison.

Dual supply overhead and diesel trams are used in a small number of cases on systems such as Kassel and Nordhausen in Germany. In these cases more or less conventional low-floor trams have been adapted to operate either from an overhead supply or from a small on-board diesel engine. The diesel engine is used to allow the trams to operate over a non-electrified local railway line.

The Nordhausen diesel trams run for about 3km in electrified mode and then for 12km in diesel mode on the section of railway that they share with local trains. In this instance three new trams for the urban tram fleet were supplied in a modified form to operate the railway service. Although the concept appears to work well it is a specific response to a specific local need. The trams do not operate in diesel mode when traversing the tramway system and the infrequent local rail service is clearly quite different from an intensive urban tramway.

For the Edinburgh system it has been assumed that a hybrid diesel/electric car would operate from an overhead supply for most of the route length of either Line 1 or Line 2 and from its on-board diesel engine and generator only within the World Heritage Site, a distance of about 2.0 km. It has been assumed that the diesel engine would be shut down when travelling over the electrified sections, rather than kept idling when not being used. This would be more energy efficient and attractive for passengers than the alternative of keeping it running all the time, but would mean that the starter motor and battery would become the potential weak link since the tram would be entirely dependent on them twice in each round trip.

Wire-Free Traction System Technology Review

The fact that a small number of such hybrid cars are already in commercial service may be regarded as “proof of concept” but it does not answer the detailed questions that would arise for a system such as Edinburgh. The Nordhausen cars are only 19 metres long, compared with the 30 or 40 metres being considered for Edinburgh, and are equipped with a diesel engine capable of delivering the equivalent of 180 kW at 4,000 rpm. When operating in electric mode they have a nominal rating of 400kW.

A 30m tram of the type required for Edinburgh would typically have between 400 and 500 kW of installed power (more if the duty cycle and route profile required it). The 40m cars for systems such as Dublin, Bordeaux and Brussels are rated at up to 720 kW.

The power rating of the Nordhausen trams when in diesel mode is thus a reflection of the different requirement created by a lightly graded railway line with widely spaced stations compared with an urban tramway. It is clear that a vehicle of this type would not come anywhere near to meeting the performance requirements for an intensive urban tramway operation.

Weight: The diesel unit adds about 0.3 tonnes to the car weight. A hybrid vehicle with a battery would probably weigh significantly more, say 0.7 tonnes.

Re-fuelling: For the type of duty envisaged, under which the diesel engine would be used for only 4.0 km in each round trip, overnight re-fuelling at the depot would be adequate. The fuel tanks would add to the weight of the hybrid vehicle and to the space required.

Noise and vibration: Although the engine compartment could be sound-proofed as with a modern diesel train, there is no doubt that some additional noise and vibration would be apparent.

Vehicle life: The life of the tram would probably be affected very little by the conversion, although some complications might arise as it got older. The diesel engine itself and its auxiliaries would have a more limited life and it should be assumed that the tram would be re-engined up to three times during its life.

Vehicle availability and reliability: Availability of a diesel/electric hybrid vehicle would be lower than for its straight electric alternative. The diesel engine and other additional equipment would affect both availability and reliability. It is unlikely that availability would exceed say 85% compared with an availability of about 95% for a conventional tram.

Vehicle compatibility with infrastructure: The use of diesel-powered trams would raise some environmental concerns and detract from the ‘ambience’ of the system, but they should be compatible with the basic infrastructure. Some re-design of the depot would be necessary, safety implications would have to be re-examined in a number of areas and it would be necessary to ensure that their performance would be adequate under all circumstances.

Passenger Capacity: The passenger capacity of the trams would be reduced by the equivalent of about 14 passengers under peak loading conditions due to the loss of floor space. The provision of uprated diesel engines, to come closer to matching the performance of the trams in electric mode, would add substantially to the weight and the space required. The passenger capacity would be reduced correspondingly.

Performance: The performance of the diesel-electric hybrid when in its diesel mode would be significantly less than the alternative electric tram.

Capital and operating cost: Both the capital and the operating costs would be significantly greater than for the conventional alternative.

Summary: The hybrid diesel/electric option either with or without the addition of a traction battery is essentially the same as all the other options based on the same principle but which use

alternative fuels, such as LPG. The addition of a battery might permit performance to be improved or the size of the diesel engine reduced but in either case it would be at the expense of additional weight and cost.

By including its own prime mover, this option does not create the same degree of uncertainty as to its range and reliability that some of the other on-vehicle options, such as flywheels and capacitors do, but it would be inferior in terms of its performance, passenger capacity and general environmental impact. A hybrid vehicle would be considerably more complicated than a conventional electric tram and would be less reliable and have a shorter economic life. In addition its direct operating and maintenance costs would be significantly higher than for an electric vehicle. Though suitable for a track sharing role on local railway lines in outer areas, for which it has been designed, it would be quite unsuitable for the operation of high frequency services at the heart of a prestigious urban tramway.

5 OFF-TRAM OPTIONS

5.1 Ground Level Power Supply

Systems of ground level power supply were used on electric tramways from the earliest days and until about 40 years ago. These were of two main types: systems that supplied traction power to the tram by temporarily energising a series of discrete contacts in the highway as the tram moved along (surface contact) and systems that supplied power to the tram from a continuous protected conductor installed below the highway (conduit).

The first of these systems (surface contact) ceased to be used after quite a short period. This was mainly because the system relied on raising and energising discrete contact studs as the tram moved over them and de-energising and retracting them as it moved on. It proved virtually impossible to do this safely and reliably on a regular basis.

Systems of the second type (conduit) were much more extensive and continued in operation for several decades in major cities such as London, Paris, Washington and Bordeaux until the first generation tramways was abandoned. This method of current collection required the provision of a continuous slot in the highway which greatly increased the cost of track construction and maintenance and was regarded as a hazard to other road users.

The conduit current collection system has not been used for over forty years and no work has been done on its reintroduction for any of the large number of new tram systems that have been planned and built worldwide in recent years. It would not now be possible to reintroduce the system in its previous form, as it would not meet present safety standards. The cost and timescale involved in re-engineering it would be substantial, even if a workable arrangement could be identified.

Although surface contact systems (as opposed to conduit) ceased to be used more than a hundred years ago, a considerable amount of work has been done by a number of contractors, mainly in France and Italy, in recent years to re-invent it for tram and bus systems. Ansaldo developed the STREAM surface contact system that was purchased in 1998 for a single line in Trieste. So far as we are aware the system has not achieved an independent safety validation and is not in public service.

The most significant work has been carried out by Alstom in France, mainly as result of their acquisition of the Innorail company. The resulting system, called APS, was selected by Bordeaux after they had considered the alternatives, including STREAM, and has now been in commercial operation on the new tramway there for about two years. Other possible applications are being considered in France but so far it is the only one that has been implemented.

The Bordeaux tramway has been examined to establish its characteristics and performance as part of the technology review for Edinburgh. This is the system that is considered in the rest of this section.

The system that has been applied in Bordeaux consists of a single central switched steel conductor rail about 200mm wide which is installed some 12mm above the height of the two running rails. The conductor rail is divided into alternating 8 metre 'energisable' and 3 metre 'dead' sections. The movement of the tram along a section of the track switches on the traction power to each of the 8 metre sections in turn as the tram runs above it. The tram collects current via a pick-up shoe mounted on one of its trailer bogies as it passes over the energised section of rail. The presence of the tram above the energised section ensures that it is not accessible to the public while it is energised. Before the tram leaves the section of rail and leaves it exposed again the power is switched off. By that time the tram is running above the next section which is also energised to maintain continuity of current collection.

The complete ground level power system is safety critical and subject to the creation of a 'control loop' between the tram and the track section concerned. Each track section is also monitored via the tramway SCADA network. The arrangements for switching and control become more complex where crossovers and junctions are involved.

A confidential report on the system is set out in Appendix A. The main points that emerge are that:

- The system appears to perform the basic function for which it was acquired in that a frequent service is maintained without overhead equipment in the central area.
- However considerable teething problems have been experienced although these may now be becoming less significant.
- The conductor rail must be installed about 12mm higher than the running rails to ensure good drainage. This requires a special profile for the road with a secondary camber between the running rails. This is likely to cause problems for road traffic on shared sections, particularly as British practice (following problems that were experienced in Sheffield) has been to off-set the traffic lane in relation to the tram track under such circumstances in order to reduce the risk of cars running on the tram rails with their relatively low skid resistance.
- Depending on the degree of segregation chosen this could apply to about 2 km of route and a number of road junctions within the World Heritage Site.
- Bordeaux does not experience significant snow and ice and as a result the roads are not gritted in the winter. The problems that are likely to arise in Edinburgh from the presence of snow and ice include the additional risk of skidding on the smooth surface of the conductor rail and the corrosive effect of the ingress of salt and water on the rail assembly.



Figure One

The installation in the city centre of Bordeaux is shown in Figure One.

Experience in Bordeaux in a more benign climate than that of Edinburgh is that to date the system has been relatively unreliable. A typical modern overhead system may be expected to experience a problem which delays the service for 5 or more minutes about once every 5,000 hours or more. The APS system in Bordeaux was quite unreliable in the early days, however after 22 months in regular service it caused such a delay less than every 1,000 hours. It may be assumed that the initial problems, which mainly arose from the water-proofing of the connection boxes installed in the roadway at 22 metre intervals, have now been resolved.

The Bordeaux trams are limited to a maximum speed of 50 k/mh (30 mph) when operating in APS mode for reasons of safety and are not able to brake regeneratively in this mode (although that was part of the original specification). In addition to having the APS collector gear on one of the trailer bogies the Bordeaux trams also carry about 0.8 tonne of traction batteries and a fully rated braking resistor. The battery is to allow them to continue to run when sections of the APS power supply system have failed locally. As with the other battery options already considered above this does provide some operational advantages.

The installation of the first system outside France in the wetter and frequently colder environment in Edinburgh would almost certainly generate a new series of problems. While these would probably be overcome in time, the cost of doing so and the effect on service reliability in the interim might be substantial. This could adversely affect the image of the tramway and its commercial performance during the all-important early stages.

Wire-Free Traction System Technology Review

Weight: The weight of a standard tram would be increased by about 3%, due to the traction batteries and current collectors.

Re-fuelling: There would be no requirement for re-fuelling

Noise and vibration: The use of the APS system would have no significant effect in terms of noise and vibration although the noise of the ground power current collector would be noticeable when operating in that mode.

Vehicle life: There should be no effect on vehicle life, apart from the need to replace the battery at intervals.

Vehicle availability: Vehicle service availability would be slightly less than for a conventional tram due to the batteries, ground power current collector and associated control circuitry including the safety critical vehicle-mounted switching unit.

Vehicle compatibility with the infrastructure: The vehicle and the infrastructure would have to be designed as a unit and there should be no compatibility issues. The tram could make use of other suitable secondary technologies such as capacitors or batteries if advantageous.

Passenger Capacity: The capacity of the trams should not be affected although the implications for the passenger payload of the additional weight would have to be assessed.

Performance: The top speed of the tram would be significantly reduced, to 50km/h, when operating in APS mode, but this should have little impact within the World Heritage Site. A few seconds delay would be enforced during the changeover from overhead to APS current collection.

Capital and operating cost: The capital and operating costs will be substantially greater than for a conventional system. It is difficult to quantify the additional cost involved because of the method of procuring such a system for which there is only one supplier. Indications so far are that Alstom would not be prepared to sell the APS system without the trams to go with it. The extent of any re-design that might be required and arrangements for obtaining safety approval for its use in the UK are also difficult to assess at present.

Since the installation in Bordeaux has still to settle down at an acceptable network-wide level of reliability, it is not clear what the long-term maintenance costs will be. It is clear however that whatever the final figures the costs will be significantly higher than for a well-designed overhead system, which is normally a relatively low maintenance item.

Improving energy efficiency by means of regeneration has been one of the major advances of the past couple of decades. The inability of trams to regenerate when in APS mode and thereby save energy will add significantly to overall power costs.

Summary: The APS ground power system was selected by Bordeaux after extensive research as the best available option if overhead was not to be used. It is however more expensive to construct than the conventional alternative and is likely to remain so whatever refinements are carried out to it. It meets the objectives that Bordeaux set for it but has not yet achieved a level of operational reliability equivalent to that of a modern overhead system.

While undoubtedly subject to very high levels of safety assessment and independent validation, including advance testing on another French tramway, it is unclear precisely what process would be required to obtain approval for its use within the road in the UK, but it would certainly involve HMRI and the City of Edinburgh. Other agencies are also likely to be involved and interest groups will also have a view. The additional safety issues that would be raised by the very different climatic conditions in Edinburgh also mean that very little of this work could rely on the precedents that have already been established in Bordeaux. It would involve a fresh start. Resolving these

issues, if they are capable of being resolved, would be likely to involve a number of agencies and take some time. It would not be compatible with the project programme.

A further complication is that APS is a proprietary system which is under the control of Alstom. Present indications are that they would be unwilling to sell the APS system including the current collection and safety-critical track section switching equipment for installation on a fleet of trams unless they were also supplying the vehicles. It is unclear how this could be reconciled with tie's procurement strategy.



Figure Two

While the APS system undoubtedly avoids the need to install overhead equipment in the areas where it is employed, it is not without its own visual impact. This is due to the need to install the contact strip throughout such sections and the control boxes every 22 metres. Other boxes are also sometimes required locally. Although such matters are essentially subjective, the visual impact is clearly significant at ground level when compared with a pair of tram rails. The effect at a tramway junction is shown in Figure Two

5.2 Other Options

As noted in Section 3 above, although there have been many developments in the field of tramway engineering in recent decades and these have led to significant gains in performance and operational efficiency, virtually all of them relate to the refinement of conventionally powered trams. There has been little work on infrastructure based options apart from the APS system. Even here the city of Bordeaux has had to take responsibility for getting the product developed. The options that they examined and rejected several years ago, such as the Ansaldo contact system, do not seem to have progressed in the interim. Thus there does not appear to be any equivalent alternative system available.

Although in theory it would be possible to re-invent a system such as conduit current collection using modern materials and construction methods this has not been done and there is no prospect of such a development being available within the timescale required for the Edinburgh Tram Network. Any new system would also have to go through a long process of development and safety certification.

An alternative to overhead electrification which was used in Edinburgh for several decades is that of cable traction. With this system a tram is pulled along by a moving cable running at constant speed within a slot in the road. The car is attached to the cable by means of 'grip' device which allows the cable to be 'slipped' on the approach to tram stops and junctions and picked up again in order to accelerate again.

Edinburgh had a large cable operated tramway until it was electrified in the 1920s and essentially the same technology is still in use on the predominately tourist cable cars in San Francisco. In slightly different forms it is used in one or two other places including, without the grip mechanism, the Great Orme Tramway at Llandudno. This operates to a limited extent within roads that are used by local traffic. The San Francisco cable car system was largely re-built a few years ago and some more modern construction techniques were used in the process. The whole process served, however, to show how complex, expensive and disruptive such a system is to build.

The re-introduction of such a system in a UK context would raise major safety issues. In addition much of the technology would have to be re-invented and hauling large and relatively heavy light rail vehicles by this means, as opposed to the light wooden bodied cars formerly used would be a major challenge. Other disadvantages are that operational performance would be restricted due to the use of a relatively slow constant speed cable, power would still be required on the cars to power their auxiliaries and the inter-working arrangements between the two lines and Line 3 in the future would raise some significant issues.

In the 1980s and 1990s a considerable amount of development work on modern cable hauled systems was done in France, mainly by the SK Soule company. Ski lift technology was used as the basis for these developments. Although some installations were built ambitious plans for a number of short cable-operated lines in Paris using a large number of relatively small cars have never been realised. It appears that major technical and financial problems were encountered particularly with a proposed system for Charles de Gaulle airport and that as a result no further development has taken place. Internationally a number of cable hauled airport shuttles have been implemented but these are all fully segregated and do not represent public transport applications.

None of the applications either historically or more recently have involved the mixed use of cable haulage and conventional overhead on different parts of the same network.

The main lesson that can be drawn from this experience is that even where there is an established local market and substantial funding it is very difficult to successfully adapt established and proven ski-lift technology to a public transport application. In the context of the Edinburgh tramway the obstacles to be overcome in putting forward any form of non-standard and unproven technology are very much greater.

There do not appear to be any other systems or technologies which merit detailed consideration for Edinburgh.

5.3 Roles and Responsibilities

The roles of the SDS project team members are defined below:

Project Director

- Corporate responsibility for the delivery of the Project;

- Jointly responsible for procurement of project team and its activities;
- Strategic review and advice regarding project implementation.

5.4 Communication and Reporting Lines

Communication with **tie** and external organisations will be in accordance with the communications protocol as described in the Project Communications Plan provided in Doc Ref ULE90130-SW-SW-PPN-00008 which will form Appendix H of this Project Management Plan. **tie** Communications Manager has confirmed this plan will be issued by **tie** following consultation with PB as the SDS provider.

The lines of communication will be in accordance with Fig 3.4 below.

6 EVALUATION

6.1 Strengths and Weaknesses

The options that have been examined represent all those that are potentially available for a wire-free traction system. There are only a limited number of ways in which the provision of wire-free traction could be approached and while there are other possibilities these are essentially variations on the same themes.

The main features of each of the options are summarised in the table below. They are evaluated against the standard criteria in Section 6.2.

Table One

Option	Strengths	Weaknesses
Traction batteries	<ul style="list-style-type: none"> - Ability to operate off-line for a limited period. - Can provide a back-up to overhead traction in the event of power failure 	<ul style="list-style-type: none"> - High weight and first cost. - Limited operating range. - Relatively high maintenance requirement and high maintenance cost combined with limited battery life.
On-vehicle flywheel	<ul style="list-style-type: none"> - Improved energy efficiency. - Limited ability to operate away from an overhead supply. 	<ul style="list-style-type: none"> - Not yet commercially available. - At an early stage of evaluation. - If offered likely to be as a means of improving energy efficiency rather than for off-line capability. - Maintenance and safety implications have still to be disclosed.
Fuel cells	<ul style="list-style-type: none"> - Ability to deliver high levels of power as and when required 	<ul style="list-style-type: none"> - Not yet commercially available for rail applications. - Likely to be relatively expensive in first cost when available - Maintenance and life cycle costs not available - Could be safety implications
Capacitors	<ul style="list-style-type: none"> - Potential to deliver significant energy savings on a network basis. - Some ability to operate away from an overhead supply - Have been in revenue service on a limited basis for over two years and have been reliable. 	<ul style="list-style-type: none"> - Additional cost and weight. - Limited performance away from the overhead. - Life of units still to be established - Maintenance implications have still be established but experience is significant and increasing
Diesel	<ul style="list-style-type: none"> - Completely independent of power infrastructure. 	<ul style="list-style-type: none"> - Additional cost, weight and maintenance. - Loss of passenger space - Increased cost and complexity of depot - Limited life of mechanical parts and effect on life of tram. - Not available in a low floor tram format - Unlikely to be compatible with alignment geometry - Performance more suited to a suburban or regional railway. - Would compromise the design of tramway infrastructure.

Wire-Free Traction System Technology Review

		<ul style="list-style-type: none"> - Noise and pollution would be greatly increased - Overall quality of the system would be reduced
Diesel as auxiliary power	<ul style="list-style-type: none"> - Could be used in conjunction with one of the other alternatives, such as batteries, to extend range. 	<ul style="list-style-type: none"> - Some loss of passenger space and payload - Loss of performance - Best suited to allow trams to operate onward extensions of little used railway infrastructure rather than in city centres - Could provide a dual mode capability operating on engine/battery in city centre and from overhead supply elsewhere - Would add to the cost and complexity of the depot
Liquid Petroleum Gas	<ul style="list-style-type: none"> - An alternative fuel source with 'greener' characteristics 	<ul style="list-style-type: none"> - Not realistically available. - A sub-option to diesel traction.
Surface contact system (APS)	<ul style="list-style-type: none"> - Freedom from overhead equipment over substantial parts of the route. 	<ul style="list-style-type: none"> - Obtaining safety approval in a UK context from both road and rail safety authorities could be very difficult and time consuming. - Differences in climatic conditions (particularly snow and ice) compared with Bordeaux could be a major problem. - Capital and operating costs would be higher. - Proprietary nature of system likely to preclude competitive procurement of infrastructure and trams - Would be more visually intrusive at surface level particularly in areas with 'heritage' paving - Some operational limitations
Alternative technology - Cable	<ul style="list-style-type: none"> - Long-established technology and used extensively in Edinburgh in the first part of last century - Used in a different form for dedicated shuttles and has been proposed for urban applications. 	<ul style="list-style-type: none"> - Safety approval likely to be a major problem despite historic precedents. - Operational performance would not match requirements. - Would be very expensive to install and maintain. - Reliability and extendability would be major issues. - Not compatible with mixed use on different parts of the network.

The Edinburgh tram system is a prestigious project which will be required to deliver a high-quality reliable public service for the capital city of Scotland. As such, while innovative solutions may deliver some benefits, any technologies used must be fully proven, low risk and capable of delivering a reliable service in a cost-effective manner. In addition they must be reliably deliverable within the project timescale and not expose the programme for the rest of the works to undue risk.

From the summary in Table One above it can be seen that although the details vary from one option to another all of them have substantially more weaknesses than strengths. In addition none of the weaknesses are trivial and none of the options stand out as being very close to being acceptable for an urban tram application.

Wire-Free Traction System Technology Review

Although 'lack of performance' has been referred to where it is an obvious weakness, the lower level of reliability that all the options would provide should also be noted. Another feature that would apply to most of the options is that of having to change over from time to time from the overhead system to an alternative. In the case of the APS system this would take place in a tramstop at the beginning and end of the APS section. The stops used for such changeovers would be equipped with both overhead and the ground power conductor. The process would take about half a minute and suitable interlocks would be built into the tram to avoid both systems being in use at the same time. Whether this would avoid all possible causes of human error is unclear. One of the reasons why little used crossovers have been wired on some electrified railways is because of the near inevitability of trains being driven across them with the pantograph raised at some stage, with consequent damage to both the overhead and the train.

Changeover arrangements and protective measures would have to be devised for each of the other alternatives. While arrangements such as simply ramping the contact wire out of running at the beginning of an unwired capacitor or flywheel section and bringing it back down again at the end might sound straightforward, they would produce other complications and would be likely to make the overhead more rather than less obtrusive at the changeover point and the trams more obtrusive throughout the unwired sections due to their pantographs being fully extended.

There would be problems obtaining a number of the options particularly within the project timescale, in addition others such as the APS system are unlikely to be available competitively without distorting the procurement process

6.2 Assessment

The different options have been assessed under the standard headings set out in Technology Review Scoping report and in Section 2 above.

The ranking of the various options against the standard criteria is summarised in Table Two below. In the evaluation process 'quality' has been taken to mean quality in the specific context of how each of the possible solutions would be perceived if applied to the Edinburgh tram system as currently defined and 'risk' to mean the risk to the project in terms of the overall performance of the tramway if that option were to be implemented.

The headings that have been used in the table are:

- Functionality – ability to deliver against the requirements specification
- Availability – both for installation and ongoing operation
- Impacts – including construction and visual
- Safety
- Hazards
- Costs – both initial cost and ongoing cost
- Risk profile – in the first instance and subsequently
- Reliability, Availability, Maintainability And Safety (RAMS)

Table Two

Solution	Time / Availability	Cost	Quality	Safety	Risk	Aesthetics	RAMS
Battery	Yes	Medium/high	High	Good	High	Good	Good

Wire-Free Traction System Technology Review

Flywheel	No	Medium	Medium	Unknown	High	Good	Un-certain
Fuel Cell	No	High	Un-known	Unknown	Very high	Good	Un-certain
Capacitor	Yes	Medium	High	Good	High	Good	Good
Diesel	No	Medium	Very low	Medium	Very high	Poor	Poor
Diesel hybrid	Yes	Medium	Low/ Medium	Good/medium	Lower	Medium	Medium
APS Surface contact	Yes	Very high	Medium	Requires clarification in the local context	High	Good apart from effect on paving	Poor
Cable	No	Very high	Low	Medium	Very high	Moderate	Very poor

From the table it will be seen that none of the options can be given a 'clean bill of health'. In some instances this is with respect to their suitability for meeting the basic objective of being able to operate for a worthwhile distance away from an overhead wire. In other cases the qualifications relate to more basic matters such as safety.

The alternatives that require extensive special infrastructure, such as APS and cable traction, are the most expensive. The alternatives that involve the installation of an independent prime mover on the tram are among the cheaper ones to implement, though still more expensive than the a conventional overhead system. However, they diverge very substantially from the specified level of performance and reliability.

7 SUMMARY AND CONCLUSIONS

The physical extent of the tramway within the World Heritage Site means that because of their strictly limited range and performance many of the options would not be able to provide a useful wire-free system even within a limited area and can therefore be ruled out. Unfortunately, the options that fall into this category are those that might have produced some secondary benefits, primarily in terms of energy conservation.

None of the alternatives look particularly attractive by comparison with a conventional well designed overhead contact system, even without their inherent limitations of range and performance. If overhead is taken as the base option then all the alternatives suffer from the fact that they would be more expensive to build and maintain and would impose operational restrictions. Reliability and availability would be worse than for the base option and the longer-term implications of the additional equipment involved, including life cycle costs, are unknown in many cases.

Some of the alternatives would also produce an environmental impact, such as the noise and fumes from a diesel engine or the additional equipment installed within the paving, although others such as batteries would not have these negative effects. There would be safety implications from the use of some of the alternatives, such as the additional risk of skidding created by the APS conductor in the road surface, or the potential hazards associated with high speed flywheels or high temperature fuel cells.

A number of the solutions would involve a reduction either in the space available on a tram for passengers, due to the additional volume of equipment to be housed, or in the passenger payload that could be carried. The passenger payload would have to be reduced to keep the trams overall weight, axle loading and weight distribution within the design limits.

For anything other than a solution that involves adding equipment for energy storage or supplementary power to a standard tramcar there would be major problems in obtaining a suitable vehicle within the required timescale. The cost of modifying a standard tram would be likely to be significant: anything more radical could be very expensive, assuming that there was a supplier sufficiently interested to quote for it. In the UK market this in itself is a large assumption.

Virtually all the options would create regulatory and 'approvals' issues to a greater or lesser extent. Solutions that centre on energy storage on the tram, such as batteries and capacitors, are likely to raise a lot fewer issues of this type, but even here the possibility of a tram becoming stranded away from the power system in the city centre is likely to be cause of concern to other organisations including the police, the emergency services and the bus operators. The level of disruption that this could cause if it occurred at a key road junction in the rush hour could be considerable.

Because the alternatives have weaknesses and drawbacks which vary in nature they are difficult to rank objectively. Since the implications of having to gain approval to the use of new equipment of a novel type such as APS or hybrid traction are particularly onerous, those options which simply add another piece of equipment to a more or less standard tram, for example for energy storage, must be regarded as the 'least risk and 'least bad' overall.

Of the solutions that involve adding equipment to an otherwise standard tram, super capacitors seem to offer the greatest potential benefit, primarily because of their contribution to energy conservation together with their limited off-overhead capability.

At the present time there does not appear to be a straightforward alternative to the system-wide use of an overhead contact system. For that reason it appears that work should proceed on the basis that the whole of the system should be wired, at least initially. In parallel with that, the tram procurement process could take into account the possible wider benefits from the use of super

Wire-Free Traction System Technology Review

capacitors and test the market to see what is on offer at the time, at what price and with what guaranteed level of performance. It might then prove possible, for example to leave certain emergency crossovers unwired and to use the energy storage system when operating through them, although that may involve more complication for little advantage.

8 APPENDIX A – REPORT ON THE BORDEAUX APS SYSTEM

To: Chris Mason **At:** Edinburgh Project Office

Copies to: Paul McCauley **At:**
Ian Sproul

From: John Baggs **At:**

Date: 18 October 2005 **Ref:**

Subject: BORDEAUX - APS GROUND POWER SYSTEM

Confidential Report on visit to Bordeaux Tramway – 14th October 2005.**Present:**

Roger Jones	–	tie
Thierry Ficat	-	'Mission Tramway', Bordeaux Municipality
Christian Buisson	-	Transdev France
John Baggs	-	SDS

Purpose of Visit:

The purpose of the visit was to inspect the APS surface contact system installed in Bordeaux and to establish what the operational experience with it has been.

Background:

M. Ficat gave an introductory talk on the subject of the Bordeaux tramway and the political background, followed by a presentation on the system. He offered to supply a copy of the presentation which Transdev will circulate when it is available.

The Tramway:

Phase 1 consisting of 3 lines and 24.5 kilometres was opened in 5 stages between 21st December 2003 and September 2005. Phase 2 consisting of a further 19 kilometres will be opened between 2007 and 2009. The total cost of the network will be Euro 1.03bn at 1999 prices. A fleet of 70 trams is being procured at a cost of Euro 169M. These are predominantly 40m long although some 30m trams are operated at present. The cost of Phase 1 was Euro 550.34M, or Euro 22.43 per kilometre, which appears attractive given the investment in the city centre, workshops and other items.

Other costs were Euro 3.81M per track/km, 0.34M per substation, 0.5M per OLE track/km, 1.5M per APS track/km and 2.4M for the complete signalling system. A total of 120 separate contracts were awarded.

One depot and workshop (cost Euro 31.6M) has been provided for all three lines, although a separate stabling facility will be provided as part of Phase 2. Depot journeys are time consuming because of the indirect routing involved and because they have to observe all tram stops. This is a contractual issue with Alstom who argue that maintenance access to the APS system is severely restricted since trams are moving on the system for 22 1/4 hours rather than the 20 hour operating day that was specified.

The system and the construction programme have been configured so that it will not be necessary to go back into the central area to carry out further construction work in the future although both Lines A and C terminate on the northern edge of the central area ready for onward extension into the suburbs. Much environmental improvement work was done in the city centre at the same time as the construction of the tramway, although it was not clear to us how the separate budgets had been allocated for this.

The construction of the tramway involved the first application to a tramway of the new French Safety Regulations. Although they were not in force at the time when the process started it was decided to work to them from the outset. The broad principles appear to follow a CDM pattern except that all aspects of the project have to be reviewed by independent experts approved by the government. Some 300 reports had to be assessed. A separate file has to be maintained for each innovation such as the APS.

On Phase 2 there will be a level crossing of an SNCF electrified line and a swing bridge over the river – both are treated as innovations. There was some 'semi in-house' involvement in the process in respect of the safety of the overall system due to the need for specific knowledge (Certifer were responsible for the tram and Ligeron for the infrastructure), but this would not be permitted in future.

Due to the fact that they are likely to end up with two teams of experts disagreeing, M. Ficat said that the French systems now believe that the independent safety review will cost about 1% of the overall project cost.

The APS System:

The system had been selected because of the following:

It was required by the French Ministry of Culture

The Fire Brigade insisted on it to maintain access to the face of buildings in narrow streets

Many old buildings are too low and the stonework is too weak to support OLE

There was strong political support for a 'wire-free' system.

The centre of Bordeaux is a World Heritage Site, though this does not appear to have been a direct influence.

Three alternative wire-free current collection systems were examined, including one developed by Ansaldo, before the Innorail APS system was selected. All of them were at the 'concept' stage. Innorail were subsequently acquired by Alstom.

The development of the system was funded by Bordeaux and the technology was proved initially on a 1km segregated section of tram route 68 in Marseilles.

Achieving a high standard of safety was seen as of paramount importance before the system went into service and the independent safety certification was achieved with 12 months of the award of contract. Reliability was given less attention at that stage.

A number of operational scenarios were examined as part of the safety evaluation and special operating procedures developed for dealing in a safe manner with matters such as a derailment on the APS section. Operation of the tram's emergency brake isolates the APS system. A four monthly meeting is held with the Safety Authority to review experience with the system, any incidents and outstanding matters. The steps being taken by the contractor to deal with outstanding matters are examined at these meetings.

Wire-Free Traction System Technology Review

The contract for the trams and track system was awarded to a JV of Alstom, Spie and Cogifer. M. Ficat thought that much less effort had been put into adapting the tram initially than was actually required. The problems with the tram related mainly to such matters as the traction batteries and the support of auxiliary demands such as the air conditioning. The battery was supposed to be rated to enable the tram to be driven at a speed of up to 60km/h and for a distance of up to 1400m. In practice because of problems changes have been made to the trams auxiliary circuits and all the batteries are currently being replaced by Alstom after 2 years.

Alstom have a 10 year fixed price contract for the maintenance of the APS system.

The present lengths of the three lines and the proportions with APS are approximately as follows:

Line	Overhead Current Collection	APS Current Collection	Total Phase 1	Planned Total including Phase 2
Line A	8.66	3.78	12.44	19.90
Line B	4.14	5.16	9.30	15.40
Line C	1.33	1.47	2.80	8.00
	14.13	10.41	24.54	43.30

It is expected that Phase 2 will involve between 10 and 13km of additional APS current collection.

Apart from the conductor rail, the installation in the street involves the provision of a box every 22m to house the CA unit. This is a modular assembly which is located at a short neutral section and which houses the control circuitry and the 750V switches which supply the two 8m long energised sections to each side of it. It contains the control logic for energising and de-energising the two sections fed from it and is regarded as a safety-critical item which is removed and worked on only by Alstom.

The rail is supplied as a factory made unit and is formed on site to fit the horizontal and vertical curvature. This was described as being a relatively easy operation. The minimum curve radius on the system is 18m. Some of the trackwork that has been installed using the APS system is relatively complex with crossovers, flat crossings and double junctions. The junction of lines B and C involves a four track tram stop and a skew crossing of the two lines with a separate link for depot workings.

The general standard of track construction including rail welding is exceptionally high and the cars give a quiet smooth ride on both street track and segregated sections whether paved or grassed. On APS sections the 'clack-clack' sound of the current collector is noticeable in the vicinity of the trailer bogie that it is mounted on.

Trams change over from OLE to APS and vice versa at a tram stop. The operation is carried out by the driver as passengers board and alight. At off-peak times when fewer passengers are around at these locations this extends the stop time by a few seconds. APS is installed in long sections running outwards from the centre of Bordeaux. Some short sections were installed in the suburbs so that the different municipalities could each claim to have a section of APS. It is possible that some of these short isolated sections, which have no real justification, will be converted to OLE in due course.

All APS sections are centrally monitored via the scada system. Apparently the driver does not normally notice the loss of power for one or two sections. In the event of a tram coming to a standstill on a failed section the driver has to operate the battery changeover switch: the tram then reverts automatically to APS as soon as it reaches a live section.

Operational Performance:

The operation of the tram system is impressive although Roger Jones had observed some poor timekeeping the previous day (this appeared to be a staff issue rather than a technical problem). The system is fully accessible to the mobility impaired. All platform faces have a substantial outstand of about 100mm plus a rubber moulded section about 50mm wide bolted to the face of them. Despite this and the fact under the safety case all trams have to stop at all platforms even when running out of service all tram doorways are fitted with sliding threshold plates on a pair of rotating arms. The trams appear to continue to run in service when these have failed at individual doorways. The leading corner of a number of the platform edge units appeared to have been struck heavily by road vehicles at suburban stops on Line B.

The reliability problems with the APS system have been identified as poor drainage (the design has been changed since the early days), water tightness, corrosion of power cables (due to acid attack) and the CA units themselves. The CA units are currently at design version 'J' though not all units presently in use have been upgraded yet. Some modifications are still outstanding and reliability problems are still being isolated and rectified on the original sections.

The safe switching of power supplies to each track section is controlled by the combination of an RF signal from the tram to the track, the detection of the loop formed by the presence of the tram's collector shoe and a safety loop which links a number of adjacent CA units. Each CA unit is linked to the scada system. Substations are placed more or less every kilometre but the same spacing and the same power system design is maintained for either APS or OLE current collection.

Based on an interruption to service of 10 minutes or more, the reliability levels for the three lines during September were as follows:

Line A	-	99.74%
Line B	-	97.46% (EMI problem identified at one location)
Line C	-	100.00%

Over the past 12 months the average has been 98.4% but Thierry Ficat thought that it had now improved considerably. The tram system is intensively used with frequencies down to 4 minutes in the peak and daily patronage at up to 180,000 compared with the prediction of 130,000.

Debris, Coke cans etc on the APS rail have been a problem and the driver on the first tram in the morning is responsible for checking that each section of track is clear.

Trams are limited to 50km/h when operating on APS because of the risk of leaving a live section exposed for a short period if travelling at a higher speed. Although Alstom's contract calls for regeneration to be available with either mode of current collection this is not achieved with APS due to concerns about safety and Ficat didn't seem to think that it would be without a major re-design.

There are a large number of road crossings on nominally segregated sections of tramway and long sections where the track in one direction is used by road traffic for servicing and access. The paving material used is predominantly blacktop outside the central area and stone flags or setts within it. Problems have been experienced at a number of shallow angled road crossings with heavy road vehicles breaking up the surfacing; it is likely that in these areas a concrete form of road construction will be adopted, despite resistance from the planners.

The APS rail is heavily polished by road traffic at busy road crossings. The twin contact strips on the top of the APS rail have only a nominal upstand of about 5mm; it remains to be seen how rapidly these will wear under constant road traffic or how difficult the process of rail replacement will prove to be.

Issues for Edinburgh

- Achieving reliable operation on a sustained long-term basis
- Obtaining UK safety certification, particularly in view of the different climatic conditions compared with Bordeaux and Marseilles including higher rainfall, snow, ice, salt and slush
- The low skid resistance of the relatively broad APS rail and the safety implications for road traffic of the internal camber required within the four-foot to promote drainage
- Keeping the rail clear of obstructions and debris
- Although visual intrusion is eliminated at “sky level”, the installation in the street is significantly more obtrusive than would otherwise be the case. This applies particularly within paved areas where otherwise only two tram rails would be visible
- The lack of a competitive market. There is only one supplier available and although Bordeaux are committed to buying their trams and track from the existing suppliers for the foreseeable future but are already conscious of the lack of competition. This would be a major problem for Edinburgh as the safety critical items are found both on the track and the trams: the two would have to be procured from a consortium able to supply and integrate both together with the necessary safety certification.
- The need for information on the long term performance of the APS track and its wearing elements under heavy road traffic

Actions

- Extract material on APS for use in Technology Review of Wire-free traction power systems
- Obtain further details from Alstom on traction batteries required for APS together with weight and cost
- Obtain copy of the Bordeaux PowerPoint presentation.



Wire-Free Traction System Technology Review



Wire-Free Traction System Technology Review



Wire-Free Traction System Technology Review



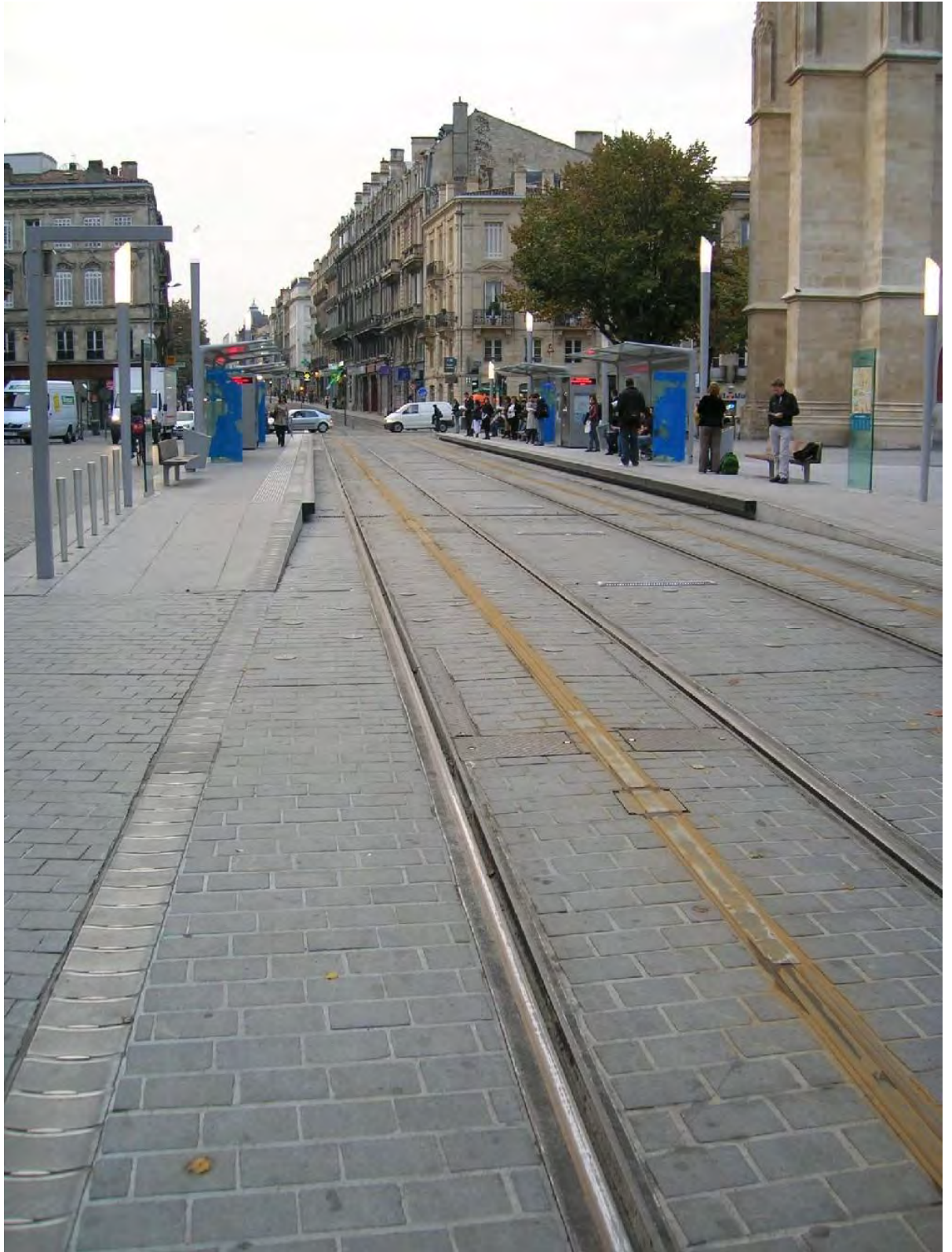





Bombardier PRIMOVE vehicles.



Alstom APS tram passing Cathedral of St Andre, Bordeaux. PHOTO: Shutterstock.com



No wires - Alstom APS tram passes Place de la Bourse, Bordeaux. PHOTO: Shutterstock.com

[Trams without wires](#)

28 Nov 2012 · by [David Shirres](#) · in [Featured rail engineer Rail News](#), [Light Rail](#) · [4 Comments](#)

For those working on heavy rail, the way streets absorb tram infrastructure to show only running rails is impressive indeed. Even more impressive is that some streets are now absorbing the tram's power supply as well, the result of a drive by the major tram manufacturers to make trams more attractive by eliminating the need for overhead wires.

This is actually a far from new idea as early trams collected current from ploughs in below-street conduits. These were connected to the tram through a slot in the centre of the tramway but were labour intensive, expensive to install, and vulnerable to items dropped in the slot. Blackpool has one of the world's earliest electrically powered tramways. When it opened in 1885, it was powered by a conduit system that was converted to an overhead supply 14 years later. The conduit didn't like Blackpool's sea and sand.

For modern trams, there are now various second-generation catenary-less systems of which ground level supplies are just one solution. Others include the latest energy storage technology and overhead top-up at stations. All are the fruits of a commitment to innovation by manufacturers to challenge the conventional idea that trams must be powered from an overhead catenary.

As these companies compete for their share of the worldwide expansion of light rail systems, they strive to make their products attractive to their customers, the city authorities. They, in turn, need to convince the people of the city. Eliminating overhead wires removes visual intrusion which is a critical factor in historic cities. Moreover, utility work for its poles or fixings on people's houses can also result in objections. Although public opinion is a significant issue, it will also be seen that energy efficiency and lower infrastructure costs also provide good reasons not to erect tram wires.

Ground Force – French-style

Alstom's Alimoitere Par le Sol (APS) was the first second-generation catenary-less tram system. It began operation in Bordeaux, a UNESCO world heritage site, in 2003. Up until 1958, Bordeaux's trams used the conduit system, and it had been assumed that the new trams would operate similarly. However it was decided that, as the old conduit system was not suitable, the new trams would have overhead wires. The resultant protest from both the public and the French Ministry of Culture resulted in the development of the APS system which is used for twelve kilometres of Bordeaux's 44 kilometre tram network.

Alstom's APS consists of a conduit, flush with the ground, on top of which are 8 metre long contact strips alternating with 3 metre long insulated segments. Inside this conduit are the supply cables and an antenna. There is a power supply box adjacent to every other insulated segment that feeds the adjacent contact strips. These are energised only when the antenna detects that the tram is wholly above the contact strip. To maximise power transfer time, contact shoes are in the centre of the tram.

The APS system had some initial teething problems. Like Blackpool in 1885, one of its initial problems was seepage and moisture. This required electrical housings and insulators to be redesigned. Now that these issues have been resolved, the Bordeaux tram system is 99.8% reliable and the city is now satisfied that it has a robust, reliable system.

Alstom claim that the installation cost of APS is comparable with that of tram catenary wire as the APS conduit requires minimal civil engineering work, being only marginally deeper than the slab track. In contrast, particularly in complex city areas, a catenary may require utility work for its masts and significant legal costs may arise if it has to be fixed to adjacent buildings.

A potential cost issue is maintenance of switchgear, with power supply switch boxes embedded in the street every 22 metres. Alstom advise that these are modular units which can quickly be replaced. Maintenance is by programmed replacement over a long period of time, enabling the units to be overhauled at service centres.

APS is also now in use as part of the Angers, Reims and Orléans tram systems. Outside France, work has started on APS tramways in Brasilia and Dubai which are planned to open in 2014. In Dubai the trams will have brushes to keep the contact strips clear of sand.

The Alstom APS system is not the only ground-contact system on the market. In Italy, Anasaldo have developed a modern version of the original conduit system. This has flush conductor and

return rails in the centre of the tramway. In the troughing beneath is a flexible ferromagnetic belt which is lifted by magnets on the tram to energise the conductor rail. As the running rails do not carry return current, the system can be used for buses. The first use of this system will be on a section of Napoli's tramway at the end of this year.

Looped power

Also at ground level, but invisible, Bombardier's PRIMOVE system is entirely hidden by the city's streets. PRIMOVE uses buried inductive loops between the tracks to transmit power to trams. These loops need to be covered by a 40mm layer of non-conductive material such as resin, asphalt base or non-reinforced concrete which may need to be carefully installed or it might be vulnerable to heavy traffic.

Each looped cable segment is eight metres long and transmits 200kw. It is fed by an inverter which transforms 750 volt DC into 200 kHz AC. This system has transmission efficiencies of between 90% and 95%, which Bombardier advises is only 2% less than contact systems.

Like APS, PRIMOVE is only switched on when the tram is above it by a maintenance-free solid-state unit. Power transmission loops are generally located at stations and gradients as required by the tram network. The loops fit above sleepers and so involve no additional civil engineering costs.

Unlike APS, it does not continuously power the tram so energy storage is an essential aspect of the PRIMOVE system. Bombardier's MITRAC Energy Saver uses super-capacitors and was originally designed to store energy from regenerative braking. Trials have shown savings of up to 30% of traction energy.

The PRIMOVE concept has been successfully demonstrated in Augsburg where Bombardier low-floor trams have been using it on an 800 metre spur line to the city's exhibition centre since 2010. Further testing has been done at Bombardier's e-mobility hub in Mannheim which opened in September 2011 and which has also tested PRIMOVE buses, minivans and cars from 3.6kW to 200 kW.

Trolley buses without wires

As PRIMOVE vehicles are not limited to rail or a fixed route, its equipment can easily be fitted to road vehicles. A battery powered bus running, say, 250 kilometres per day requires a six or seven ton battery. Bombardier have calculated that if PRIMOVE is used for charging, only a one ton battery is required and that a single charge point, located at a central part of the bus network could, typically, provide 20 charges a day with no effect on the bus service. Charging buses in this way also extends battery life. Thus for minimal infrastructure investment, it could enable a city to operate a fleet of electric buses with the same performance as diesel buses.

Although PRIMOVE buses would seem to offer huge environmental and cost benefits, these have yet to be demonstrated in practice. To demonstrate this concept, a pilot programme of PRIMOVE bus operation is planned for five cities in 2013 – Bruges and Lommel in Belgium and

Augsburg, Braunschweig and Berlin in Germany. These pilots involve various types of buses of up to 200 kW and 18 metres long. In Braunschweig, the German Ministry of Transport has given a grant of €2.9 million for the PRIMOVE bus pilot on a 12 kilometre section of its bus network to become operational autumn 2013.

PRIMOVE's greatest potential impact is its use in cars. To test this concept, the Lommel pilot bus scheme includes tests with a 22kW Volvo C30 car. Until now, battery size, range and time-to-charge have been insuperable constraints to the widespread introduction of electric cars. By removing these constraints, PRIMOVE has the potential to change motoring as we know it.

The storage solution

Siemens have been building trams since they provided the world with its first electric tram, powered from overhead wires in the Berlin suburb of Lichterfelde in May 1881. It's therefore no surprise that they also offer trams without wires using their Sitras HES (Hybrid Energy Storage). This system has been in use in Lisbon, Portugal since November 2008 and has been selected by Qatar for its Doha tramway which will be operational in 2015 as part of the preparations for the 2022 World Cup.

HES is a modular system that can either be built into new vehicles or installed in existing trams, enabling them to run for distances up to 2.5 km without wires. It comprises two 820kg roof mounted units: a nickel-metal hydride cell (NiMH) battery and an MES (Mobile Energy Storage) unit using double-layer "super capacitors". Batteries have a higher energy density than super-capacitors but take longer to charge. In the HES unit the respective stored energy of batteries and super-capacitors is 18 kWh and 0.85 kWh whilst the respective power output is 105 kW and 288 kW. For this reason, HES uses super-capacitors for acceleration and batteries for steady speed. Another advantage of such storage systems is that they eliminate power spikes when several trams accelerate at the same time.

Unlike APS or PRIMOVE, Siemens HES trams require an overhead supply. This may be conventional overhead wires on part of the network or a Sitras LCU (Local Charging Unit). The LCU is a short length of overhead conductor rail placed at stations or other stops that can deliver a 1,000 amp charging current during a typical 20-second station dwell time. HES is also charged from regenerative braking, which Siemens claim can reduce energy consumption by 30%.

A similar system has been developed by Spanish manufacturer CAF. This uses its ACR freeDRIVE which, when used in conjunction with the ACR evoDRIVE, developed to save energy from regenerative braking, offers up to 1.4 kilometres of catenary-free operation. It has been used on a 1.6 kilometre section of Seville's tramway since 2010 and is also in use in the Spanish cities of Zaragoza and Granada .

In Nice, Alstom have fitted their Citadis trams with extra NiMH batteries for 500 metres catenary-free operation across two historic squares. On the Paris T3 tramline, a Citadis tram has been fitted with a bank of 48 supercapacitors to simulate catenary-free running.

Alstom is also trialling flywheel storage on a tram in Rotterdam. This is roof-mounted and runs in a vacuum at speeds around 20,000 rpm providing a net energy storage of 4kWh and 325 kW peak power. It will be interesting to see if a modern flywheel can compete with the increasing use of super-capacitors.

And the winner is....

With UNIFE predicting a 9.3% increase in the world's urban rolling stock market over the next 5 years, tram manufacturers are doing all they can to increase their market share and catenary-less trams are one way to do this. However, the technology is quite novel. The oldest system, Alstom's APS, is less than 10 years old and has now proved itself in service, although initially it had significant teething problems which have been resolved. Other systems offer great potential but are quite new and have yet to be subject to the intensive use needed to demonstrate their reliability.

All these systems have their pros and cons and what is best for one city will not be for another. For these reasons it would be wrong to name the best system. However, with its potential to increase the number of electric vehicles on the road, PRIMOVE offers an interesting potential environmental benefit.

The real winners are cities that now do not have to erect tram wires in their city centres. This not only preserves historic centres, but, in complex city centres, could reduce construction and utility costs. However, the case for catenary-less trams outside the city centre is less clear.

Another surprising winner, albeit in the long term, may be the motorist for whom fuel pumps could be a thing of the past as they drive PRIMOVE electric cars with the performance and range of today's cars. Transferring technology from rail to road in this way shows just how innovative rolling stock manufacturers have become. There are, no doubt a lot more innovations to come.

Feasibility of Alternative Power Supply Systems for the LUAS BXD

20 April 2012



1. INTRODUCTION.....	4
1.1 PURPOSE OF THE DOCUMENT	4
1.2 SYSTRA.....	4
1.3 EVALUATION CRITERIA	4
1.4 REFERENCE DOCUMENTS	5
1.5 VISIT ON SITE.....	5
2. KEY FEATURES OF THE SECTION OF THE BXD LINE UNDER STUDY.....	6
2.1 GRADIENT AND DISTANCE BETWEEN STATIONS.....	6
2.2 RUNNING ENVIRONMENT	6
2.3 IMPACT OF ROAD TRAFFIC ON TRAMWAY OPERATION	7
3. OVERVIEW OF THE CATENARY-FREE SYSTEMS AVAILABLE ON THE MARKET	8
3.1 SYSTEMS BASED ON ON-BOARD ENERGY STORAGE	8
3.1.1 CAF Super Capacitor system	8
3.1.2 Siemens Super Capacitor system Sitras MES / Sitras HES.....	9
3.1.3 On-board battery by Alstom.....	10
3.2 SYSTEMS BASED ON A CONTINUOUS POWER SUPPLY	10
3.2.1 APS by Alstom.....	10
3.2.2 Tramwave by Ansaldo.....	11
3.2.3 Primove by Bombardier	13
4. ANALYSIS OF FITNESS FOR PURPOSE.....	15
4.1 SUITABILITY OF CAF SUPER CAPACITOR SYSTEM.....	15
4.1.1 Fitness for shared running	15
4.1.2 Conclusion	16
4.2 SUITABILITY OF SIEMENS SUPER CAPACITOR AND BATTERY SYSTEM	16
4.2.1 Fitness for shared running	16
4.2.2 Conclusion	16
4.3 SUITABILITY OF ALSTOM BATTERY SYSTEM.....	17
4.3.1 Fitness of shared running.....	17
4.3.2 Level of deployment.....	17
4.3.3 Conclusion	17
4.4 SUITABILITY OF BOMBARDIER PRIMOVE SYSTEM	17
4.4.1 Fitness of shared running.....	17
4.4.2 Level of deployment.....	18
4.4.3 Conclusion	18
4.5 SUITABILITY OF ALSTOM APS SYSTEM	18
4.5.1 Fitness for shared running	18
4.5.2 Resistance to weather conditions	20
4.5.3 Impact of APS technology on electric distribution scheme	21
4.5.4 Feasibility of fleet retrofitting	21
4.5.5 Safety considerations	21
4.5.6 Energy efficiency.....	22
4.5.7 Level of deployment.....	23
4.5.8 Conclusion	23

4.6	SUITABILITY OF ANSALDO TRAMWAVE SYSTEM	24
4.6.1	<i>Fitness for shared running</i>	24
4.6.2	<i>Impact on electric distribution scheme</i>	25
4.6.3	<i>Resistance to weather conditions</i>	25
4.6.4	<i>Feasibility of fleet retrofitting</i>	25
4.6.5	<i>Safety considerations</i>	26
4.6.6	<i>Energy efficiency</i>	26
4.6.7	<i>Level of deployment</i>	26
4.6.8	<i>Conclusion</i>	26
4.7	CONCLUSION	27
5.	INDUSTRIAL CAPACITY	29
5.1	SITUATION OF ALSTOM	29
5.2	SITUATION OF ANSALDO	29
5.3	CONCLUSION	29
6.	EXTENT OF THE RETROFIT	31
6.1	OPERATIONAL REQUIREMENT AND CONTEXT	31
6.2	TECHNICAL CONSEQUENCES	31
6.3	CONCLUSION	31
7.	INVESTMENT AND OPERATING COSTS	33
7.1	INVESTMENT COSTS.....	33
7.1.1	<i>Alstom APS</i>	33
7.1.2	<i>Ansaldo Tramwave</i>	34
7.2	OPERATION AND MAINTENANCE COSTS.....	34
7.2.1	<i>Alstom APS</i>	34
7.2.2	<i>Ansaldo Tramwave</i>	34
7.2.3	<i>Cost Summary</i>	35
	APPENDIX 1 - TERMS OF REFERENCE FOR REPORT ON ALTERNATIVE POWER SUPPLY SYSTEMS	36
	APPENDIX 2 - REFERENCE DOCUMENTS	37

1. INTRODUCTION

1.1 Purpose of the document

An Bord Pleanála as part of its deliberations to determine whether the LUAS City Broombridge (BXD) project should be granted consent to proceed, has employed SYSTRA in order to examine the feasibility of employing an alternative to the Overhead Contact System (OCS)¹.

An alternative traction system is envisaged for portions of the BXD line that would run in visually sensitive areas of the city centre of Dublin: from St. Stephen's Green to the north end of O'Connell Street (about 1.7 km). Alternatives have been examined in terms of technical feasibility. Additionally, we have provided elements regarding industrial availability and cost. The terms of reference drawn up by An Bord Pleanála are provided in Appendix 1.

The objective of this work is to provide the Board with further information, clarification and assistance on the subject - independent of the project developer - to facilitate its decision regarding employment of an alternative system to OCS on the LUAS BXD.

1.2 SYSTRA

SYSTRA is a world-leading engineering consultancy specialising in urban and rail transport. We work on all stages of transportation projects, from master plans and feasibility studies up to project execution and technical assistance for operations and maintenance. SYSTRA is involved in transport projects around the world, and boasts numerous references working with light rail systems.

SYSTRA has been involved in the implementation of alternative power sources for light rail systems in Dubai, Qatar, Rheims and Bordeaux.

1.3 Evaluation criteria

In this document we evaluate and compare the available alternative technologies, and we identify to what extent they would be applicable to the LUAS BXD requirements. The following points are explored.

System reliability

The reliability of each system is examined, taking into account the specific conditions of the BXD line, in particular shared running and climate conditions.

Suitability (and safety) for the proposed level of shared running

¹ OCS can also be referred to as “overhead line” or “catenary”. We use both the terms “OCS” and “catenary” throughout this document.

We will evaluate the suitability of each system for the proposed level of shared running with cars, buses, bicycles, etc.

Ability to cope with adverse weather conditions

Specific attention is paid to the ability of systems to deal with adverse weather conditions such as heavy rain and snow.

Energy considerations

Energy considerations are examined with regards to the technical characteristics of each possible solution.

Retrofitting on existing fleets of trams

We evaluate the technical possibility of retrofitting existing fleets of trams.

Capital and operational costs

We estimate capital and operational costs associated with the alternative system(s), as compared to OCS.

Industrial capacity

We examine industrial capacity for delivery of each possible solution. In addition, attention is paid to the constraints that the choice of each solution will impose for the future: dependence on a single provider or not, degree of deployment of the system in other LR networks...

Prior deployment

An Bord Pleanála has suggested that the main focus should be for a system that has already been proven on an existing in-service tramway.

1.4 Reference documents

As part of its consideration, SYSTRA has referenced a suite of selected documents, drawings and information including EIS documents and oral hearing submissions (see full list attached as Appendix 2 to this report) provided by An Bord Pleanála.

1.5 Visit on site

In addition to the above documents, SYSTRA representatives visited the offices and met with representatives of An Bord Pleanála, visited the LUAS depot at Sandymount (accompanied by a representative of An Bord Pleanála) and inspected the subject area of the report and existing LUAS running arrangements during a visit to Dublin on the 7th and 8th March 2012.

2. KEY FEATURES OF THE SECTION OF THE BXD LINE UNDER STUDY

In order to be able to assess the technical feasibility of an OCS-free power supply in the section of the BXD line between St. Stephen's Green and the north end of O'Connell Street, the key features of this section must be understood and analyzed, especially those which may have an impact on the potential technical solution.

The compliance of the various technical solutions to the requirements identified here is assessed in chapter 4 of the current document.

2.1 Gradient and distance between stations

Gradient and distance between stations are of particular concern for some OCS-free power supply systems.

In the case of the section under study, the maximum distance between two adjacent stations is about 480 m (between the Dawson and the Westmoreland stations), and the maximum gradient is less than 1.5% (between St. Stephen's Green and Dawson).

Both values are low enough that they will not pose particular problems for any of the OCS-free power supply solutions evaluated.

2.2 Running environment

Two key characteristics of the BXD running environment between St. Stephen's Green and the north end of O'Connell Street are the following:

- Along most of the section, the tramway shares its track bed with road traffic.
- Some of the alignment sections are narrow (from façade to façade); as such, bulky equipment will need to be accommodated in underground technical rooms.

These two features lead us to identify two requirements:

- Any equipment installed in the track bed must be able to withstand heavy road traffic, without adding potential hazard to road users.
- Space requirements for equipment to be installed along the line should be kept as low as possible.



Example of section with both heavy traffic and tight space for the new line

2.3 Impact of road traffic on tramway operation

The sharing of the track with road traffic along most of the section under scrutiny has an obvious potential impact on tramway operation, as trams risk to get stuck in traffic.

In addition to that, we learnt from RPA during our visit in Dublin that the level of priority given to trams at intersections is decided by the city council. Current policy is to provide limited priority to trams during peak hours in order to avoid blocking road traffic running perpendicular to the tram route.

These two factors mean that tram operation is likely to be impacted upon by traffic, such that trams will have to stop and start several times between two stations.

Therefore, the OCS-free power supply solution must be able to handle a situation in which trams may be forced to stop and start multiple times between any two stations, without risk that trams may be left stranded without power in the middle of dense traffic.

3. OVERVIEW OF THE CATENARY-FREE SYSTEMS AVAILABLE ON THE MARKET

The purpose of this section is to provide a high-level understanding of the various solutions currently proposed by tramway providers to ensure the supply of power without an overhead catenary.

These systems can be classified in two main different categories:

- Systems based on on-board energy storage
- Systems based on a continuous power supply from the track bed

For each of these concepts, various solutions are proposed by rolling stock manufacturers. The following paragraphs provide an overview of the main technical and operational features of the available systems.

3.1 Systems based on on-board energy storage

The three following solutions all rely on an on-board energy storage device which supplies the tram while it runs on sections without an overhead catenary.

3.1.1 CAF Super Capacitor system

3.1.1.1 Operating principle

The system proposed by CAF is based on a Rapid Charge Accumulator, branded ACR by CAF, which stores energy in super capacitors² to feed the tram.

There are two situations in which the ACR is charged:

- A partial charge when regenerative braking is used
- A complete charge when the tram is stopped at a station that precedes an OCS-free section

Stations are equipped with a short section of overhead rigid catenary, and the tram raises its pantograph when it stops in stations.

The power stored in the ACR is used in two situations:

- On the section fitted with OCS: during the acceleration phase to reduce the current peak drained from the OCS

² Super capacitors are particularly high-bandwidth energy storage devices. They can store large amounts of energy very quickly and can also release energy very quickly. A battery, on the other hand, takes more time to store energy and releases it more slowly.

- On the OCS-free section: to feed the train during its whole trip until the next station

3.1.1.2 Key features

The super capacitors (also called “super caps”) used to store energy are the key component of ACR.

The benefit of using super caps is to make it possible to transfer a great deal of power in a short period of time. The super capacitors are charged during the dwell time which should last between 20 and 30 seconds, depending on the length and gradient between stations.

3.1.1.3 Life expectancy

The super capacitors are under high stress because they go through permanent charge-discharge cycles.

They require a temperature control system (dedicated air conditioning unit) in order to avoid operation under high temperature that would be detrimental to their life expectancy.

Manufacturers indicate that their life expectancy is estimated to be from 7 to 10 years, depending on the actual mission profile of the OCS-free sections.

3.1.1.4 Use of batteries

In order to cope with some particular configurations (exceptional distance between two stations, trams equipped with powerful air conditioning or heating), the super capacitors may be associated with batteries.

The batteries contain more energy than super capacitors, but the maximum current acceptable at a time is much lower, so the charge/discharge cycle takes place on a longer time scale. The batteries are charged when the trams run on sections equipped with OCS, and slowly discharged on the OCS-free sections.

3.1.2 Siemens Super Capacitor system Sitras MES / Sitras HES

3.1.2.1 Operating principles

The operating principles of the Siemens solution are identical to those described above for the CAF solution, i.e. the tram is powered by on-board energy storage device(s) when running on OCS-free sections.

3.1.2.2 Specificity of Sitras MES / Sitras HES

Siemens proposes in its standard solution a mix of batteries and super capacitors.

The batteries supply the constant background load, whereas the super capacitors supply the power peaks and store the energy produced by regenerative braking.

3.1.3 On-board battery by Alstom

3.1.3.1 Operating principles

The solution proposed by Alstom and Saft for the tramway in Nice, France, relies on on-board energy storage as well.

In this case, energy is stored in Nickel Metal Hydrure (Ni-MH) batteries when the tram runs on sections equipped with OCS, and this energy is used on OCS-free sections.

3.1.3.2 Key features

The distance that can be covered while running on an OCS-free section with this solution depends on the battery capacity and the length of the preceding OCS section where the batteries are charged beforehand.

The solution implemented in Nice covers two sections for a total length of about 900 m.

On these sections located in the historical centre of the city, the tram crosses pedestrian areas at low speed.

It has to be noted that operation on batteries reduces the achievable rate of acceleration, the maximum speed and possibly the commercial speed.

3.2 Systems based on a continuous power supply

3.2.1 APS by Alstom

3.2.1.1 Operating principles

Alstom's APS system is based on traction power supplied to the vehicle by a power rail located between the running rails. The rolling stock uses a current collector shoe to obtain power via physical contact between the collector shoe and the track-embedded power supply rail.

The power supply rail is divided into 8 m long segments separated by 3 m long insulation segments.

The rail is fed with 750 V DC from "power boxes" embedded in the track.

Segments of power supply rail are only activated when they are completely covered by a tram vehicle.

This principle ensures a live rail is never accessible to pedestrians. Loops embedded in the track bed detect the presence of a vehicle via a coded radio signal emitted by the trams. This energy-distribution principle through segmentation is illustrated in the figure below.

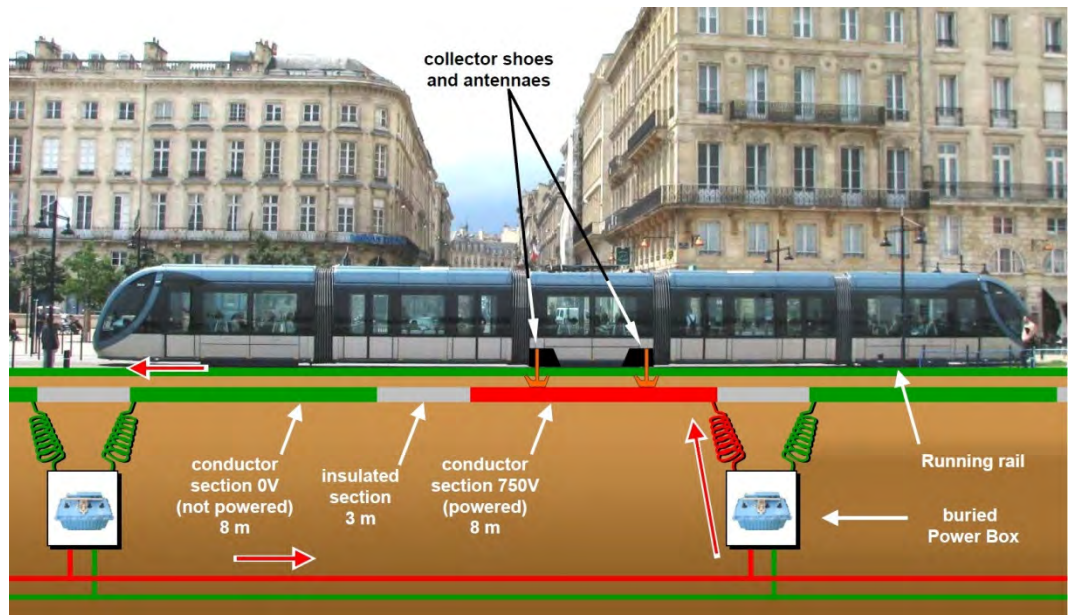

When there is no vehicle over a given section, the rail is electrically connected to the return-current circuit (0 V) to avoid any unwanted powering up of the APS rail.

APS allows for catenary-free sections of any length, or even on the whole line.

Transitions between APS sections and catenary-equipped sections require that the tram come to a full stop. Practically, the transition is made within stations so that dwell time can be taken advantage of in order to minimise the impact of the transition time.

3.2.1.2 *Specific features*

The maximum operating speed on APS sections is 50 km/h, while an Alstom Citadis vehicle can operate at 70 km/h with overhead catenary.

In order to mitigate local failure of the system, the vehicles are equipped with batteries. These batteries enable trams to cross failed sections of up to 50 meters.

3.2.2 *Tramwave by Ansaldo*

3.2.2.1 *Operating principle of the Tramwave system*

The Tramwave system provides trams with a continuous 750 DC power supply thanks to modules embedded in the track between the running rails.

The power is collected through a collector shoe. For safety reasons, only the modules located beneath the tramway collector shoe are powered up, so the hot part is never accessible to the pedestrians.

The powering up of the sections under the collector shoe is ensured by a relatively simple electromechanical solution: the collector shoe contains a powerful permanent magnet which lifts a metallic belt contained in the track-embedded module. When this belt is positioned in the upward position, contact is ensured between the 750 V DC feeder running along the Tramwave module (“internal positive feeder” on the upper left of the drawing below) and the “internal elements variable polarity” (on the upper right of the drawing) and the metallic surface segment on the top of the module. The part labelled as “internal elements variable polarity” is permanently connected to the “surface segment” (top of the drawing), so the “surface segment” is brought to 750 V DC potential.

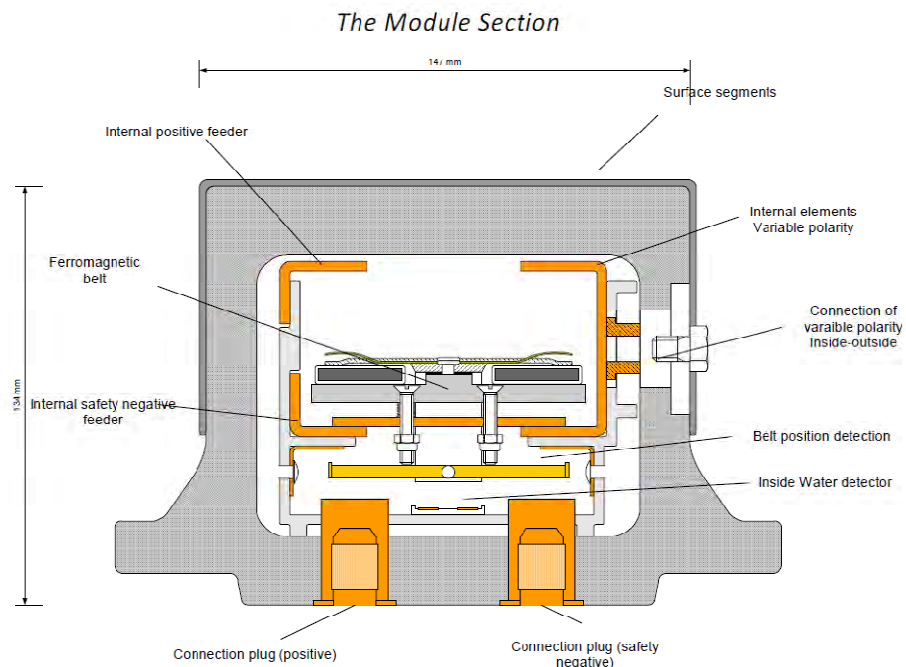

Tramwave power rail cross section (© Ansaldo)

When the belt is positioned in the downward position, the part labelled “Internal elements variable polarity” is connected to the “Internal safety negative feeder” through the lower part of the belt and thus the metallic surface segment is connected to the negative feeder. The negative feeder is connected to the 0 V pole of the substation (as well as the running rail).

The safety of the Tramwave system is based on the fail safe principle: in the event the metallic belt remains stuck in the upward position after the collector shoe has left the zone, the lower part of the belt will fall due to its own weight and connect the metallic surface segment to the internal safety negative feeder. At this point, there is a short circuit

between the positive and the negative feeder, leading the high speed circuit breaker to trip immediately.

The Tramwave modules are supervised from the operating control centre (OCC): the operator can monitor the electrical status of each section.

In addition, the presence of water inside the module is detected by a dedicated captor and the corresponding alarm sent to the OCC.

An on-board battery can carry the tram along a section in which the track bed modules malfunction.

On a recent bid, Ansaldo proposed on-board super capacitors to improve energetic efficiency. These super capacitors have a much lower capacity than those proposed on CAF and Siemens solution because they are not the primary source of power.

3.2.2.2 Operation of the collector shoe

The collector shoe contains the permanent magnets which lift the belt in the platform-embedded module.

For safety reasons, these magnets are made up of several magnets and are arranged in a way such that they repulse each other (S-N N-S S-N), but they are kept together by the structure of the collector shoe. In the event of a breakage of the collector shoe, the magnets will repulse each other. Each magnet taken individually is not strong enough to lift the belt, so a broken collector shoe cannot lead to a powered module by leaving loose magnets.

The collector shoe is maintained in the upward position by a spring. In order to lower it, a hydraulic system has to compensate the force of the spring.

The force of the spring is greater than the force of the magnet, so any failure of the hydraulic system would release the collector shoe to the upward position, thus setting the rail to 0 V.

3.2.3 Primove by Bombardier

3.2.3.1 Operating principle

Bombardier's Primove solution provides continuous power to the tram thanks to induction loops embedded in the trackbed and coils installed under the frame of the tram.

Power is transmitted, without any physical contact, through the electromagnetic flux produced by the embedded loop.

The coils embedded in the track bed are powered on only when the tram is running over them to avoid unnecessary electromagnetic emission.

The tram is detected via the coded radio signals that it emits and which are received by the trackside equipment.

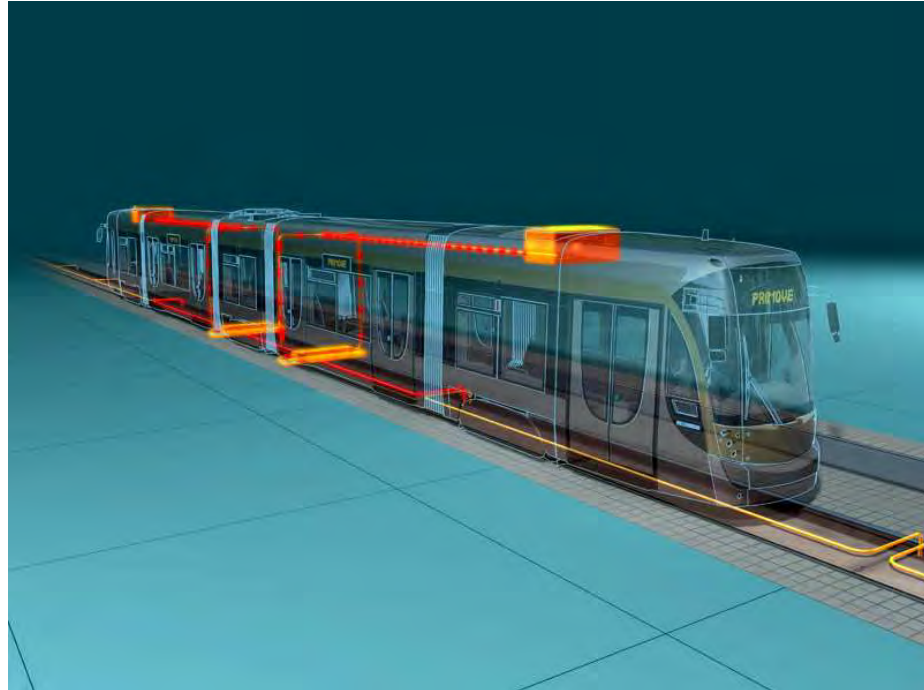

Bombardier's Primove system (© Bombardier Transportation)

3.2.3.2 *Specific features*

Although Bombardier has not revealed extensive technical details on the Primove solution, some specific technical features are known.

The amount of power the induction loops are able to transfer is less than the power transmitted with an OCS, so the Primove solution cannot deliver the power peak required to maintain constant acceleration of the tram above 20 km/h. In order to solve that problem, the tram is equipped with super capacitors which provide the required boost needed during the second part of the acceleration phase.

These super capacitors, presented as an improvement of the basic Primove solution, are in fact a mandatory feature.

The loops embedded in the track bed must be covered by a plate made of a material which does not contain any metal because metal is conductive and would shield the electromagnetic flux.

4. ANALYSIS OF FITNESS FOR PURPOSE

In this chapter we evaluate the fitness for purpose of each of the technological solutions described above. The evaluation criteria are defined in function of both the constraints linked to the BXD extension and the brief provided by An Bord Pleanála (principally reliability) and reproduced in Appendix 1.

The analysis begins, for each technology, with the constraint and criteria of the highest importance to proceed further with criteria of lesser importance. In the event one of the technologies does not comply with one of the mandatory requirements, making it unsuitable for the BXD line, the analysis is not be pursued further with the criteria of lesser importance.

4.1 Suitability of CAF super capacitor system

4.1.1 *Fitness for shared running*

4.1.1.1 Mechanical aspects

This solution based on super capacitors does not require the installation of any specific equipment in the track bed along the catenary-free section.

In other words, the track bed will be identical to the track bed implemented along the section fitted with catenary, so the super cap solution is compatible with shared running from a mechanical point of view.

4.1.1.2 Running in congested traffic

Shared running along the busiest streets of the city centre means a potential risk of having a tram stuck in traffic, requiring several stops and starts between two stations.

The super cap solution is based on the principle that the tram carries its own on-board power supply. This supply is sized to be able to cover the longest distance between stations and includes a margin to be able to face an unscheduled stop between two stations.

In congested traffic, the maximum number of unscheduled stops between stations cannot be predicted; neither can their duration (when the tram is stopped, ventilation, lighting, and other ancillary equipment keep on draining down the supply).

It seems unlikely that the on-board supply could be sized such as to **guarantee** that there would be no risk of trams running out of power (and thus getting stuck) between stations.

Moreover, sizing the super cap supply such that it could handle some predefined scenario of congested traffic would lead to a significant increase in both its size and weight.

Since a train which has run out of power has no possibility of moving without being rescued by another tram or vehicle, such an event would have a significant impact both on tram operation and road traffic.

4.1.2 Conclusion

The combination of shared running (and thus the likelihood of having to handle congestion) and a super cap on-board power supply system leads to an unquantifiable risk of having trains stranded in the middle of the city centre.

This major drawback leads us to conclude that, based on currently available information, the super cap solution is not suitable for the BXD line.

4.2 Suitability of Siemens super capacitor and battery system

From a functional and technical point of view, the solution proposed by Siemens is very similar to the CAF solution, so the arguments discussed above will be quickly summarised below.

4.2.1 Fitness for shared running

4.2.1.1 Mechanical aspects

The solution based on a super capacitor does not require the installation of any specific equipment in the track bed along the catenary-free section, so the track bed will be identical to the one implemented on sections fitted with OCS.

4.2.1.2 Running in congested traffic

The energy stored in the super capacitors and batteries is limited, and – given the shared running that is planned for this section of the BXD line – it cannot be sized to cope with all possible scenarios in terms of unscheduled stops and starts.

4.2.2 Conclusion

The combination of shared running (and thus the likelihood of having to handle congestion) and a super cap on-board power supply system leads to an unquantifiable risk of having trains stranded in the middle of the city centre.

This major drawback leads us to conclude that, based on currently available information, the super cap / battery solution is not suitable for the BXD line.

4.3 Suitability of Alstom battery system

4.3.1 *Fitness of shared running*

4.3.1.1 Mechanical aspects

The solution based on batteries does not require the installation of any specific equipment in the track bed along the catenary free section.

As already mentioned for the super capacitor based solution, the track bed will be identical to the track bed implemented along the section fitted with catenary, so the super cap solution is compatible with shared running from a mechanical point of view.

4.3.1.2 Running in congested traffic

The battery solution has two major drawbacks when it has to run in congested traffic:

- The quantity of available energy is limited, and therefore so is the number of unscheduled stops and starts that the tram can withstand between two stations.
- The maximum current which can be delivered by the batteries is lower than the current delivered by the OCS or super caps; thus the rate of acceleration that the tram can achieve is limited.

4.3.2 *Level of deployment*

Alstom has deployed its battery solution only in Nice.

4.3.3 *Conclusion*

The Alstom solution based on batteries is not designed for shared running, and would present a high risk of having trams stranded between two stations after multiple unscheduled stops.

Thus, at the time of this writing, we consider that the Alstom battery solution is not suitable for the BXD application.

4.4 Suitability of Bombardier Primove System

4.4.1 *Fitness of shared running*

4.4.1.1 Mechanical aspects

The Primove system requires the installation of embedded electrical loops between the running rails.

These loops shall be covered by a 40 mm layer of nonconductive material such as resin, asphalt base course or non-reinforced concrete.

Bombardier has not provided information regarding the long-term resistance of this arrangement under road traffic.

Moreover, Bombardier does propose that the Primove track-embedded equipment not be implanted in intersections.

These aspects lead us to consider that there are currently no satisfactory technical solutions available to meet the requirement related to heavy road traffic running over the Primove embedded loop.

4.4.1.2 Running in congested traffic

The Primove system provides a continuous power supply, which makes it possible for trams to stop and start as many times as necessary, as long as they stop over induction loops.

According to Bombardier, at low speeds (below 18 km/h), the acceleration performance supplied by Primove is identical to that provided by an OCS; thus congested traffic and repeated stops and starts are not a concern.

4.4.2 Level of deployment

At this time, the Primove system is not implemented in commercial service.

In addition to the Bautzen test track installed in Bombardier premises, an 800 m long pilot section has been installed and tested in Augsburg, Germany.

This pilot section did not carry any passenger and was segregated from road traffic and protected by fences.

4.4.3 Conclusion

The Primove System is able to face congested traffic by withstanding frequent stops and starts, but, for the moment, in its current design, it does not appear to be able to withstand the load associated with shared running, as foreseen on the BXD line.

Moreover, although the Primove System has been proposed by Bombardier in some of its bids, it cannot be considered as a proven in use system.

For these reasons, we consider that, at the time of this writing, the Primove solution is not suitable for the BXD line.

4.5 Suitability of Alstom APS system

4.5.1 Fitness for shared running

4.5.1.1 Mechanical aspects

The APS solution requires the installation of a power rail between the running rails, embedded in the track bed.

In the BXD context, the power rail must be able to withstand continuous road traffic for years, without damage.

On French projects, APS is mainly installed on segregated running sections, except for road intersections where road traffic crosses the rail.

As part of its certification process, the first version of the APS system went through an endurance test to simulate the effect of urban traffic (over 700,000 cycles with 7-ton pressure wheels).



View of the endurance test plant (© Innorail)

Despite this test and certification process, the first version of APS installed in Bordeaux in 2003 suffered damage at road intersections. It is worth mentioning that in this previous design, the APS rail was directly embedded in asphalt.

Following this experience, Alstom revised its design to embed the APS rail in a concrete plinth to increase its resistance to road traffic. This improvement ended up being satisfactory in Bordeaux.

The latest design of APS (APS 2) now includes a reinforced power rail, still embedded in a concrete plinth. Alstom claims that it can withstand 13.5 ton axle loads.

For Dubai, Alstom's design is foreseen to withstand road crossings with more than 100 buses a day.

4.5.1.2 Running in congested traffic

The APS power rail continuously provides the same amount of power as an overhead catenary, so running in congested traffic is not a concern for a tram fed by APS.

4.5.2 Resistance to weather conditions

4.5.2.1 Flooding

The APS power rail, like any power rail, cannot operate when it is covered by water, because such a situation would lead to current leak when the rail is powered up, and thus tripping of the circuit breaker protecting the traction power circuit.

Flooding of the track bed is an exceptional situation which should be prevented by an appropriate drainage arrangement embedded in the track.

Regarding the protection of the embedded power box, the latest APS design is based on an IP 68 rated box, which means, according to standard EN 60529, it can remain immersed in 1 metre of water for 15 days.

4.5.2.2 Snow and ice

On December 28th, 2006, relatively light snow falls in Bordeaux lead to the interruption of tram service on sections equipped with APS.

The layer of snow between the collector shoe and the power rail prevented proper contact and thus the feeding of the tram.

In the morning of December 29th, 2006, the snow melted during the day and then froze during the night, forming a layer of ice on the power rail, making it even more difficult for the maintenance teams to clean it. On January 24, 2007, operation was interrupted again for the same reason.

The tram operator in Bordeaux did not have specific tools or equipment for removing snow or ice from the power rail, because snow is usually not a concern with Bordeaux's relatively mild climate.

Since this episode, new equipment and practices have emerged to solve the issues related to snowfall and cleaning of the power rail in general:

- A railroad truck specifically designed for cleaning the groove of the running rail and the APS power rail is now available on the market
- Alstom now proposes the installation of heavy duty brushes in front of the collector shoe
- Specific maintenance procedures have been implemented in Rheims (in operation since April 2011), where snow fall is more significant than in Bordeaux. These include:

- Use of glycol to prevent icing of the APS rail
- Continuous operation of a tram when snow falls are foreseen to prevent the snow from sticking to the APS rail
- Ban of applying salt on the streets at a distance of less than 50 cm from the track bed, as salt water leads to current leaks and triggers the tripping of the circuit breaker

Although these measures improve the availability of APS, it is to be noted they are not an absolute mitigation of the risk related to snowfall. Recently, on February 5th 2012, in Bordeaux and February 8th 2012, in Rheims, operation was interrupted for several hours because of snow falls that prevented APS from functioning correctly.

4.5.3 Impact of APS technology on electric distribution scheme

The arrangement of the traction sub-stations is identical for APS and for regular OCS.

4.5.4 Feasibility of fleet retrofitting

APS is currently installed in other cities on Citadis 402 and Citadis 302 trams. The current LUAS fleet is made up of Citadis 401 (Red Line) and Citadis 402 (Green Line).

The retrofit of existing trams to install the on-board APS equipment would require the following modifications:

- Installation of collector shoes
- Installation of roof-mounted batteries
- Installation of antennae under the frame
- Modification of the traction circuit

The Red Line depot has been used in the past to retrofit Citadis 301 trams to become Citadis 401 trams. The necessary equipment is thus available so that the retrofit activity may be carried out in the Red Line depot.

4.5.5 Safety considerations

The electrical safety of the APS system has been demonstrated and reaches Safety Integrity Level 4.³

³ The allocation of safety integrity levels is specified in standard EN 50126. The safety integrity level varies from 0 to 4, where 4 is the highest level of safety integrity.

The French authority for the safety of guided transportation issues each year a report dealing with tramway safety. Since the opening in Bordeaux of the first tramway line equipped with APS in 2003, the impact of the APS power rail on pedestrian or cyclist safety has never been identified as a concern.

4.5.6 Energy efficiency

For safety reasons, regenerative braking is not possible when running with the APS system, thus energy efficiency is degraded by 15% to 20%.

The cost associated with this increase in the power consumption is difficult to estimate accurately at this stage. In order to carry out this estimate, many assumptions must be made; each of them introduces potential uncertainty in the result.

The main assumptions concern power consumption with regenerative braking and the cost of electricity.

The following table identifies the parameters we took into account for this rough estimate.⁴

cost per MW.h (€)	60
power consumption without regenerative braking (kW.h/tram.km)	13.5
power consumption with regenerative braking (kW.h/tram.km)	11.3
power consumption due to absence of regenerative braking (kW.h/tram.km)	2.3
duration of peak hour (h)	4
headway during peak hours (min)	5
duration of off-peak hour (h)	16
headway during off-peak hours (min)	10
length of the APS section (km)	1.7
number of runs per day	288
distance run per day (km)	478
number of km run per year (tram.km)	174,499
power consumption by year due to absence of regenerative braking (kW.h)	392,623
additional cost due to absence of regenerative braking (€)	23,557

The annual additional cost due to the absence of regenerative braking remains relatively low according to the calculation above. This is mainly due to the moderate length of the section to be potentially equipped with catenary free system.

⁴ The cost of a MW.h is of course highly variable. The energy consumption per tram.km is the result of a simulation of the running of a 43-metre Citadis 402 tram carried out by Systra on a recent project.

Alstom is currently working on improving energy efficiency by introducing on-board super caps. This solution is more efficient than reinjection of power in the OCS (the classical approach to energy regeneration), because it does not require the presence of another tram on the same section to use this power. On the other hand, the retrofit of existing trams to install on-board super caps appears to involve heavy works which would likely require reinforcement of the tram carshell.

4.5.7 Level of deployment

The APS system is currently deployed in revenue service in the following cities:

- Bordeaux (since 2003)
- Angers (since 2010)
- Rheims (since 2011)

It should be noted that on the French projects, the trams run most of the time on segregated rights-of-way, except at road intersections.

In addition to the projects mentioned above, Alstom has been awarded contracts to implement APS in the following cities:

- Orléans (2006)
- Dubai (2008)
- Brasilia (2009)
- Tours (2010)

4.5.8 Conclusion

The APS solution appears to properly address the constraints specific to the BXD line, by offering:

- Continuous feeding, to cope with unscheduled stops between stations
- A design which takes into account the mechanical stress caused by road traffic
- A high level of safety
- The possibility of retrofitting the existing fleet of Citadis 402

It also meets the requirement for a proven system.

The implementation of the APS system for the BXD line is not prevented by any major technical impossibility and appears feasible to us.

The risk associated with snow fall and ice can be mitigated by proper maintenance and operation procedures, but cannot be completely suppressed as recent experience in Rheims has shown: operation has been interrupted by ice and snow falls several times during the winter of 2011/2012.

4.6 Suitability of Ansaldo Tramwave system

4.6.1 *Fitness for shared running*

4.6.1.1 Mechanical aspects

The power rail embedded in the track between the running rails will have to withstand road traffic on the shared running zones.

The Tramwave power rail (originally branded Stream by Ansaldo) has been designed to withstand road traffic and shared running, as it was originally planned to be implemented for buses running in lanes shared with other traffic



View of a Stream power rail on via Mizzoni, Trieste (© L. Fascia)

In Trieste, the embedded power rail has been installed in 2000 to feed electric buses. Although these buses are no longer in service, the power rail has been left in the road bed ever since.

According to Ansaldo, this power rail does not show traces of fatigue or cracks.

4.6.1.2 Running in congested traffic

The Tramwave power rail continuously provides the same amount of power as an overhead catenary, so running in congested traffic is not a concern for a tram fed by Tramwave.

4.6.2 Impact on electric distribution scheme

The arrangement of the traction sub-stations is identical for Tramwave and for regular OCS.

4.6.3 Resistance to weather conditions

4.6.3.1 Flooding

As already explained for the APS power rail, the Tramwave power rail cannot operate when it is covered by water, because such a situation would lead to current leaks when the rail is powered up, and thus tripping of the circuit breaker protecting the traction power circuit.

Flooding of the trackbed is an exceptional situation which should be prevented by an appropriate drainage arrangement embedded in the track.

The Tramwave equipment embedded in the track bed is designed and tested to be watertight.

4.6.3.2 Snow and ice

Snow and ice stuck on the power rail prevent proper contact with the collector shoe and thus may disrupt operation.

The Tramwave system has not yet faced this type of problem because of the mild climate of the location where it has been implemented, but it is likely it would suffer the same kind of operational issue as APS has when exposed to snow and ice.

The solutions adopted for the APS (brush mounted on the tram and specific maintenance vehicle) could likely be adopted for the Tramwave solution.

4.6.4 Feasibility of fleet retrofitting

Tramwave is currently installed on Sirio Tram produced by Ansaldo, and a retrofit of tramways manufactured by another company has never been carried out before.

When contacted about this topic, Ansaldo's representative confirmed the potential interest of the company in such an operation and did not expect any technical impossibility.

He made it clear that in any case the possibility of a retrofit must be confirmed by thorough study of the mechanical and electrical arrangement of the Citadis 402.

The retrofit of existing trams to install the on-board Tramwave equipment would require the following modifications:

- Installation of collector shoe
- Installation of roof super capacitors
- Modification of the on-board traction circuit

The weight of the super capacitor is expected to be lower than the weight of the battery required for the APS solution, so the modification of the Citadis 402 appears technically feasible.

4.6.5 Safety considerations

The Tramwave solution has been recently granted Safety Integrity Level 4 certification by RINA⁵ for the 3 km pilot line in Napoli. The previous system (Stream) has been assessed by TUV⁶ in 1997.

The risk of pedestrians tripping is mitigated by the flatness of the power rail which is perfectly embedded.

The risk of cyclist sliding on the bare metal surface is similar to the risk of sliding on the top of the running rail, without the risk of having a bicycle wheel trapped in the rail groove.

4.6.6 Energy efficiency

The Tramwave system allows regenerative braking and current injection back to the power rail, in the same way as it is done on sections fitted with OCS.

The overall energy efficiency of the Tramwave system is even in theory slightly higher than the OCS because the copper cables included in the power rail box provide better conductivity than an OCS, although the benefit in terms of energy consumption is minor.

4.6.7 Level of deployment

The Tramwave system has not been deployed as part of a commercial project yet.

The references claimed by Ansaldo so far are the following:

- Implementation of the Stream system in Trieste from 2000 to 2002
- 400 m of test track installed at Ansaldo premises in Napoli
- Pilot line in Napoli on semi segregated running since April 2011

4.6.8 Conclusion

The Tramwave solution appears to properly address some of the constraints specific to the BXD line, by offering:

- Continuous feeding, to cope with unscheduled stops between stations
- A design which takes into account the mechanical stress caused by road traffic

⁵ RINA is an Italian company, member of the IACS (International Association of Classification Societies).

⁶ TUV is an Italian testing, inspection and certification entity.

- A high level of safety
- The possibility of retrofitting the existing fleet of Citadis 402

On the other hand, this solution does not properly satisfy two criteria identified by An Board Pleanála:

- There is no guarantee of its performance in circumstances of significant ice and snow fall
- It cannot be considered as fully proven since it has not been implemented as part of a commercial in-service project

The implementation of the Tramwave system for the BXD line is not prevented by any major technical impossibility and appears feasible to us.

The risk associated with snow fall and ice could be mitigated by proper operation and maintenance procedure but cannot be completely suppressed.

In addition, the technical risk associated with a non-proven system cannot be quantified despite the thorough testing performed by Ansaldo so far.

4.7 Conclusion

The paragraphs above analysed the suitability for BXD of the various catenary-free systems available on the market.

The catenary-free solutions which rely on on-board energy storage cannot guarantee the tram will be able to start after many stops and starts in heavy traffic.

For this reason, we consider that the solutions proposed by CAF (Super Capacitor), Siemens (Super Capacitor associated with batteries) and Alstom (Batteries) are not suitable for BXD.

The three remaining solutions under scrutiny have in common their reliance on a continuous supply of power which makes it possible for the tram to stop and start as many times as needed, thus avoiding the risk that trams may find themselves unable to start when stopped in the street due to traffic.

Amongst these three solutions, we have a major concern regarding the mechanical strength of the cover of the embedded loop in the current design proposed by Bombardier for its Primove system.

Moreover, given the constraints associated with electromagnetic flows, it appears doubtful a solution will be easily found to make Primove suitable for shared running and heavy traffic.

For this reason, we consider that, at its current stage of development, Primove is not suitable for BXD.

Alstom's APS system meets most of the requirements identified for BXD; its design addresses operation in congested traffic, mechanical resistance to heavy traffic, high level of safety.

The retrofit of the Citadis 402 fleet currently run on the Green Line is technically feasible.

The requirement for a proven system is also met, with APS deployed in Bordeaux, Rheims, Angers and Tours.

The vulnerability of the embedded power to heavy snow or ice cannot be denied, but operation procedure and technical features have been developed to mitigate this weakness.

The Tramwave solution proposed by Ansaldo, despite long and thorough testing and the implementation of a pilot line in Naples, cannot yet be considered as a proven system.

On the other hand, the design proposed by Ansaldo meets most of the operational and technical requirement identified for BXD: its design addresses operation in congested traffic, mechanical resistance to heavy traffic, high level of safety.

Based on the available information, the retrofit of the Citadis 402 to implement the on-board Tramwave component appears technically feasible to us.

In conclusion, the market does not yet offer a technical solution that would be perfectly adapted to all of the constraints of the LUAS BXD.

Nonetheless, we consider that two viable solutions, Alstom's APS and Ansaldo's Tramwave, meeting the main requirements are available on the market.

Beyond technical feasibility, contractual feasibility must also be determined.

5. INDUSTRIAL CAPACITY

5.1 Situation of Alstom

From a technical point of view, the capacity of Alstom to retrofit Citadis 402 trams is obvious and should not be a concern.

APS has not been developed to be sold as a standalone product, however, but rather to provide Alstom a competitive advantage when selling trams. We do not have information that would indicate whether Alstom would be interested in carrying out a retrofit.

The French authority in charge of ensuring fair competition among bidders in public tenders has obliged Alstom to publish a thorough description of the interface between the track-side APS equipment and the on-board APS equipment, in order to make it possible for other manufacturers to propose trams which are compatible with the APS infrastructure.

Following this publication, CAF was able to propose APS-compatible trams as part of its bid for Bordeaux's fleet extension in 2011.

5.2 Situation of Ansaldo

Although we suspect that it would be technically possible to retrofit Citadis 402 trams with on-board Tramwave equipment, this assumption would need to be confirmed by Ansaldo.

Once again, we do not have information regarding the interest that Ansaldo may or may not ultimately have for carrying out such a retrofit operation.

Tramwave is also a proprietary solution, covered by patents, and despite the simplicity of the on-board equipment, another tram manufacturer would not be allowed to provide Tramwave-compatible vehicles, except if this has been agreed upon beforehand with Ansaldo at the time the BXD section is installed.

5.3 Conclusion

The retrofit of Citadis 402 trams for use with a catenary-free system appears feasible to us from a technical perspective. We do not know, however, whether the manufacturers would be interested in carrying out such a retrofit.

The only approach to mitigate the long-term risk of monopoly for the procurement of new trams is to reach a contractual arrangement to this effect with the initial manufacturer.

Such an agreement would oblige the manufacturer to supply any future tram suppliers with the components which ensure compatibility with the catenary-free infrastructure or

to provide a detailed description of the interface between the trackside and the on-board equipment so that other manufacturers may design trams that are compatible with the proprietary infrastructure.

6. EXTENT OF THE RETROFIT

6.1 Operational requirement and context

The LUAS BXD project includes an interconnection with the existing Red Line, whereas currently no connection exists between the Green and Red Lines. This interconnection is planned to be implemented when the Green Line extension crosses the Red Line in O'Connell Street and in Marlborough Street.

The existing tram fleet of the Green Line will be used on the extended Green Line.

In addition, RPA wants the Red Line fleet to be able to run on the Green Line and vice versa.

6.2 Technical consequences

The interconnection of the two lines has deep consequences because transitions between a section fitted with OCS and an OCS-free section is usually made at station.

In other words, it means that the connection between the Red Line and the Green Line on O'Connell Street near the GPO would require retrofitting the Red Line up to the next station before the connection, to install OCS free power infrastructure in addition to the existing OCS.

The existing Green Line fleet (Citadis 402) must be retrofitted to be able to run on the extension fitted with OCS-free power supply.

The current requirement for Red Line trams (Citadis 401) to be able to run on the Green Line would necessitate the retrofit of the entire Red Line fleet, as well

6.3 Conclusion

The retrofitting of the existing Green Line fleet is a necessity and cannot be avoided. Despite its cost, the retrofit of the Citadis 402 appears feasible.

The requirement for interoperability between the Red and the Green Line fleets has a major impact on rolling stock (retrofit of 40 Citadis 401) and installation of a few hundred meters of OCS-free power supply infrastructure on the Red Line.

The technical feasibility of the retrofit of the Citadis 401 is not guaranteed at this stage, and would likely require deeper works than the retrofit of Citadis 402.

The benefit of the interoperability of the Red and Green Line is not obvious to us. During our visit, we learnt that both depots have equivalent capabilities, so there is reduced need to transfer trams from one line to the other on a regular basis.

Given the huge expected costs and reduced benefits, we do not consider it is worth implementing the full interoperability of the two lines.

A cheaper alternative to consider is to maintain the interconnection of the tracks between the two lines, without implementing the continuity of the power supply. In the event the operator wishes to transfer a Red Line tram to the Green Line depot, this tram could be towed when running over the OCS free section.

7. INVESTMENT AND OPERATING COSTS

Following the technical analyses carried out above, the cost aspects will be addressed for the two solutions which have been considered as potentially suitable for BXD line: Alstom's APS and Ansaldo Tramwave.

The information is available to SYSTRA based on past and recent involvement in bids and cooperation with operation companies.

Whilst such information cannot be site specific and has to a certain extent been generalised due to commercial sensitivities they are however based on SYSTRA's recent practical and considerable knowledge and experience in the field.

Regarding the operation scheme, *Luas Broombridge St. Stephen's Green to Broombridge (Line BXD) Environmental Impact Statement (Book 1)* states on page 109 §7.4 that the duration of the trip is expected to be 24 minutes, and the foreseen headway is 3 minutes.

From these operation parameters, we deduct the minimal theoretical tram fleet should be 16 trams (8 trams running in each direction at each given time). Since some additional trams are usually needed to provide operational flexibility, we assume 18 new trams will be purchased.

7.1 Investment costs

The investment costs provided below are based on recent contracts or bids. These costs have to be considered cautiously, keeping in mind the high variability of the prices proposed by the tramway providers from one project to another.

We have observed that, depending on the level of competition and the desire of a provider to get a first reference for a new solution, the price may vary by +/- 25%.

7.1.1 Alstom APS

The APS system is made of on-board equipment and track side equipment.

To this date, on-board equipment has always been delivered on new trams.

The cost of this on-board equipment *delivered on a new tram* is estimated to be around 300,000 €, in addition to the basic cost of the tram.

A retrofit of in-service trams to install on-board APS equipment has never been performed, so we lack references.

Nonetheless, given the specificity of the operation, we can estimate the retrofit of a Citadis 402 will add an extra 100,000 € approximately to the price of the on-board APS equipment.

In the case of a Citadis 401, more extensive modifications may be needed; we cannot estimate the cost of such an operation.

The cost of the APS track side equipment is estimated to be 1,850,000 €/km.

The overall additional cost for APS implementation is estimated to be about 19,000,000 €.

For price breakdown, refer below to 7.2.3

7.1.2 Ansaldo Tramwave

Ansaldo's Tramwave system is not yet installed anywhere. On the other hand, Ansaldo has participated in some tenders but no price was officially communicated.

Despite this lack of information, we estimate that capital costs of the Tramwave on-board and track-side equipment should be of the same order of magnitude as the costs related to Alstom's APS system.

Given the specificity of a retrofit operation carried out by Ansaldo on the Citadis 402 trams, involving significant redesign activities, we expect that the cost of retrofit will be higher than that of the equivalent retrofit made by Alstom with its APS system.

Nevertheless, we do not know the amount Ansaldo could ask for this retrofit. In particular, manufacturers may be willing to offer a competitive price if the contract is considered to be important.

7.2 Operation and maintenance costs

7.2.1 Alstom APS

The trackside APS equipment requires some maintenance effort, especially the power boxes embedded in the track bed.

The maintenance effort for the fixed APS equipment is estimated to cost 75,000 €/year/km.

In addition, the current design of APS is not compatible with regenerative braking, so the power consumption will be increased by 15% to 20% on the section equipped with APS.

As the calculation carried out in §4.5.6 showed, the annual cost associated with the relative reduction in energy efficiency is roughly 25,000 €.

7.2.2 Ansaldo Tramwave

The Ansaldo Tramwave is not yet in revenue service, so there is no information available regarding the operation and maintenance cost.

Ansaldo Tramwave allows regenerative braking, so energy consumption will not be increased as compared to OCS.

7.2.3 Cost Summary

The following table summarizes the additional investment and operating and maintenance (O&M) cost associated with the implementation of APS (as compared to an OCS-only system).

This table is based on the estimated unit costs provided above and the hypothesis that only BXD line will be equipped with APS (not retrofit of the red line fleet).

According to these hypotheses:

- 1.66 km of tracks shall be equipped with APS
- 26 trams shall be retrofitted
- 18 new trams shall be purchased (estimate based on 24 minutes trip and 3 minutes headway)

Investment cost	€
APS infrastructure	3,071,000
Cost of fitting APS equipment on new Trams	5,400,000
Cost of retrofit	10,400,000
Total	18,871,000
Yearly O&M costs	€
Additional power supply cost	25,000
APS maintenance cost	124,500
Total	149,500

APPENDIX 1 - TERMS OF REFERENCE FOR REPORT ON ALTERNATIVE POWER SUPPLY SYSTEMS

Objective

Examine the feasibility, primarily from a technical and economic perspective, of employing an alternative to the Overhead Cable System (OCS) proposed in the draft Railway Order, in the visually sensitive areas of Dublin city centre.

Considerations

The sensitive area for the purpose of the study is from St. Stephen's Green to the north end of O'Connell Street, including Dawson Street, College Green, O'Connell Bridge and the GPO. The south-bound leg of the one-way system (Parnell Street to College Street) is not considered sensitive.

The author should become familiar with the existing LUAS systems as already serve Dublin Region, and how the BXD line will integrate with same, and also longer term transport plans for the region.

The study should focus only on systems that are developed and commercially available. Systems employed in cities such as Bordeaux, but also more recently in Nice, Reims, Orleans and Angers should be included for consideration (and any other relevant locations).

Up to date information on such systems should be gathered, including consultation with system providers and operators, where possible. Up to date cost estimates should be used.

The report should identify the most relevant technology/ technologies applicable to the LUAS BXD requirements, and consider the potential for use on LUAS BXD, including:

- System Reliability
- Suitability for the proposed level of shared running (with cars buses etc.) and implications for reliability/ traffic management
- Ability to cope with adverse weather conditions, e.g. snow/ice or heavy rainfall (and possible implications for the roads authority or the environment if new response procedures are required)
- Safety implications for cyclists in a shared running environment
- Energy considerations
- Necessity and extent of retrofitting on existing fleets of trams
- Likely cost differential (both capital and operational) that an alternative to OCS would mean for the overall project.

APPENDIX 2 - REFERENCE DOCUMENTS

Title of the document
Greater Dublin Area - Draft Transport Strategy 2011-2030 - 2030 vision
Inspector report for case 29N.NA0004 by B. Wyse
Luas Broombridge Oral Hearing - Proof of evidence - Overhead Conductor System (OCS) by Paolo Carbone
Luas Broombridge Oral Hearing - Proof of evidence - Construction and Operational Traffic Management by Eoin Gillard
Dublin Chamber of Commerce - Submission to An Bord Pleanala - RPA Railway Order for Luas Broombridge (dated 13 th August 2010)
Letter: Construction operation and maintenance of a light railway system from St Stephen's Green to Broombridge, Dublin, by Alan McArdle (dated 3 rd February, 2012)
Luas Broombridge Oral Hearing - Dublin City Council - Opening Address by Gerard Meehan B.L. (dated 20 May 2011)
Luas Broombridge (Line BXD): presentation for Engineers Ireland (dated 21 February 2012)
Development of Luas & the Next Phase of implementation - Luas Broombridge: presentation by Michael Sheedy and Jim Kilfeather (dated 21 February 2012)
Line BXD Power Description by RPA, rev 01 (dated 6 march 2012)
Kylemore Ess Equipment Layout reference by Ansaldo CZ-AXX-600-EM-0078, revision Z04 dated 30/06/04
Line BXD -Structures- Substation- Broadstone reference BXD-SS-29-E-0, no revision, no date
O'Connell BXD, Broadstone Single Line Diagram, reference A-BXD-0000-PS-0002, revision A01, dated 10/05/2011
Overhead Contact System Traction Power System Distribution Single Line Diagram reference A-BXD-000-PS-003, revision A01, dated 13/05/2011
St Stephens Green Ess Equipment Layout by Ansaldo, reference CZ-XBX-600EM-0122 revision Z03, dated 20/05/04
St Stephens Green Substation Single Line Diagram, reference A-BXD-0000-PS-0001 Revision A01 dated 10/05/11
Broombridge Line and Depot Single Line Diagram, reference A-BXD-0000-PS-0004 revision A01, dated 07/05/11
Substation Relocation Works Equipment & Cable Routing Layout, reference T-MN-7178B-PS-01001 revision T01 dated February 2010
Railway Works, Line BXD - Alignment Details - Cathal Brugha St. Dominick LWR reference BXD-R0-29-C-D, dated June 2010
Railway Works, Line BXD - Alignment Details - Eden Quay to Cathal Brugha St. reference BXD-R0-29-B-C, dated June 2010
Railway Works, Line BXD - Alignment Details - Grafton Street to Eden Quay reference

Title of the document
BXD-R0-29-A-B dated June 2010
Railway Works, Line BXD - Alignment Details - St Stephen's Green West to Grafton Street, reference BXD-R0-29-0-A dated June 2010
Draft Typical Cross Section - Double Track Embedded Shared by RPA (not dated, no author)
Draft Typical Cross Section - Double Track segregated Option 1 by RPA (not dated, no author)
Luas Broombridge (Line BXD): Environmental Impact Statement (book 1 of 5)
Luas Broombridge (Line BXD): Environmental Impact Statement (book 2 of 5) Area 29 St Stephen's Green to former Broadstone railway cutting
Luas Broombridge (Line BXD): Environmental Impact Statement (book 4 of 5): Maps
An Board Pleanala: Functions of the Board (extract of a web site)
Planning & Policy: Zoning Objectives dated April 2010
Overall map of Dublin showing the Heavy Commuter Line, the Existing Tram Line and the proposed BXD (drawn by hand, no reference)
Defining Dublin's Historic Core: Realising the Potential of the City Centre and its Georgian Squares for Citizens, Business and Visitors by Geraldine Walsh, Stephen Coyne and Graham Hickey (2010)
Tram System in Bordeaux: Report on the tram System and underground Power Supply for Dublin City Business Association by Brendan Finn, dated 7 th December 2007
A spatial Vision for Dublin (April 2009) by Hendrik W van der Kamp

Overhead wires free light rail systems

Submission date: July 29, 2010.

Number of words: 5999.

Number of tables: 1

Number of figures: 5

Equivalent number of words: $5999+6\cdot 250 = 7499$ words.

Corresponding author: Margarita Novales.

Authors:

Margarita Novales. Civil Engineer, PhD. Railways Associate Professor. La Coruña University.
Address: ETS Ingenieros de Caminos, Canales y Puertos. Campus de Elviña, s/n. E-15071. A Coruña.
Spain
Telephone: +(34)981167000 Ext.:1452
Fax: +(34)981167170
E-mail: mnoval@udc.es

ABSTRACT

Light rail systems are experiencing a revival in several countries in the world. Nevertheless, they are facing a more and more demanding market which implies continuous new evolutions and technologies. An example of this fact is related to the requirement of avoiding visual intrusion in some areas of cities which are more sensitive to visual impact.

This fact has led to the implementation of new solutions that try to avoid the need for overhead contact wires through the whole network or through the lengths between stations. These solutions are based, generally, in the use of new embedded third-rail systems; the use of on-board energy storage devices; or the use of electric energy produced on-board the vehicle.

This paper is focused in the explanation of these technologies, their applicability, as well as their advantages, risks and inconveniences, in an attempt to clarify available options and their reliability.

1 INTRODUCTION

Although streetcars disappeared in many cities around the middle of the last century, nowadays a revival of this technology is taking place, in most cases improving the performance of the system by the use of type B right of way category [1], that is, giving to transit a longitudinally physically separated right of way, which will improve operational speed, frequencies, availability and punctuality of the system. Several countries can be cited as examples of this revival, such as Spain, France and the United States.

Nevertheless, nowadays light rail systems are facing a new requirement related to environmental impact, specifically to the visual intrusion produced by overhead contact system (OCS). OCS typically consists of vertical support poles located either on the center of the track, or on one or both of its sides, from which the isolators and the wires which provide electric power to the vehicles are suspended. Electrical energy is transferred from the overhead wire to the vehicle by a roof-mounted pantograph [2].

It is true that in most cases OCS should not be an important environmental problem, because the solutions usually provided for urban systems (speeds up to 70 km/h), consists only of one contact wire suspended directly from the poles, or by means of a short auxiliary wire. If this disposition is compared with the initial state of many streets (see Figure 1), it is clear that the effect of OCS will be at most similar to the one of the electrical cables existing in many cases.

On the other hand, there are several measures to minimize the negative visual effect of OCS, which are very well explained in [3].

Nevertheless, there will be some situations in which special care must be taken in relation to visual intrusion. This is the case of areas with high significance, as historic city centers, emblematic places of a metropolitan area, parkways, etc. In addition, there are some other locations in which the existence of OCS may cause problems, as when a light rail route travels under bridges without vertical clearance to allow OCS installation, or in places where it is difficult to install wires, as in tunnels or at large intersections. There are even some cities in whose centre the use of aerial wires is forbidden (as is the case of some areas of Washington DC).

Finally, OCS normally uses the track rails as a return circuit for electric power to the substations. This fact may lead to stray currents, a phenomenon by which the return current follows the least resistant path to earth instead of the rails. In the case of soil and ferrous objects stray currents cause an electrolytic effect which can rapidly corrode any electrically conducting objects and in severe cases can lead to structural failure. To prevent this from happening, important isolation measures must be taken, which can raise construction costs of light rail systems.

Through the history of trams several cases of OCS-free systems have been implemented, as it is the case, for example, of New York and Washington DC. These solutions were the result of a possibly overzealous desire by these cities to eliminate all exposed wiring in the downtown districts. It resulted in an installation that was not only much more problem-prone than OCS, but it also was more costly to construct, maintain, and operate [4].

Nowadays, mentioned reasons have led several streetcar manufacturers to search for new solutions to provide electric power for the streetcar vehicles. In many cases these solutions are quite similar to the ancient ones, although they are improved in several aspects. They can either be combined with OCS on different stretches of the network, or substitute OCS in the whole track.

These new solutions will be presented in this paper.

2 EXISTING SOLUTIONS FOR OCS-FREE LIGHT RAIL SYSTEMS

There are, mainly, three alternatives to prevent the use of contact wires in light rail systems with right of way categories C (shared) and B (reserved) [1], which are the following:

- The use of an embedded third rail (ETR), located between the running rails at the same level as the rest of the street. The traction power supply can be either by contact or inductive. In any case, as the right of way can be utilized, at least in some areas, by other street users (pedestrians, cyclist, private cars), safety must be guaranteed. This is achieved by allowing that only the areas of the ETR which are under the vehicle be energized.
- Energy storage on-board the vehicle, by means of batteries, super-capacitors, flywheels, etc. These elements will have to be charged either during the vehicle circulation, or when it is stopped at stations.
- Electric energy produced on-board the vehicle, by means of diesel-electric generators, fuel-cells, etc.

These technologies will be explained in the next sections.

2.1 Embedded third rail (ETR) technology

This technology is the only one that means a real alternative to OCS if elimination of wires along the whole network is desired. Nevertheless, existing implementations do usually not affect the whole networks, but are combined with OCS, using the ETR solution only in sensitive areas.

General advantages of this solution are:

- Preservation of the urban visual environment.
- Total safety for pedestrians and road users.
- Avoidance of access problems for emergency vehicles (as firefighters) to building facades.
- Prevention of conflicts with arboreal vegetation of the streets.

On the other hand, there are still some inconveniences in this solution, which are supposed to be counteracted with time and experience, as the concerns about its operation with rain, ice and salt; the construction and maintenance costs; and the reliability of the system.

Nowadays, there are three different ETR technologies, designed by three different companies, with their corresponding patents and with different levels of development.

2.1.1 Alstom' APS system

In this solution, the 750 V-dc ETR is made up of 8 m long conducting segments separated by 3 m insulating joints. Power is supplied to the conducting segments by underground boxes every 22 m.

The delivery of power to the conducting segments is triggered by coded radio dialogue between the vehicle and the ground, and only occurs once the conducting segment has been covered by the tram, ensuring total safety. The electricity transmitted through the ETR is picked up by two collector shoes located in the mid-section of the tram, while a block of roof-mounted batteries allows the vehicle to maintain power at stations or if a power control unit fails [5]. The whole system is shown in Figure 2.

Bordeaux (France) is the first city in the world to have opted for this completely new technology on 14 km of its 44 km long tram network. It has been operating since the end of 2003 [5].

This solution had some initial troubles, due to drainage problems in buried power boxes. These troubles were solved and APS is now operating successfully in Bordeaux at 99.8% reliability since the end of 2005. Three other French cities, Angers, Reims and Orléans, decided in 2006 to install APS on their new light rail networks, and Alstom won its first contract for a system outside Europe last year (Dubai's Al Safouh Tramway) [5].

The main advantages of this solution, apart from the general ones of ETR solutions, are:

- It is a mature technology that has been proved in actual applications (initial problems properly solved).
- Performance levels equal to those of a conventional tram in terms of comfort and speed.

The greater inconvenience of this technology, as of all ETR solutions, is related to the infrastructure's cost. Indeed, in the existing implementation the cost of each meter of APS system is around 7 times the cost of the equivalent OCS. Nevertheless, it is important to note that OCS usually represents only around 3% of the whole cost of a tramway project. If APS is applied in the most sensitive zones (for example, 30% of the network, as is the case of Bordeaux), it will lead to an increase of project' cost around $7 \cdot 3 \cdot 0.30 = 6.3\%$, which seems to be an affordable amount in a project of these characteristics. For French applications, Bordeaux is the one with a greater percentage of APS in relation to the length of the network. Only the Dubai project is going to have the complete network provided with APS.

APS leads to an increase of vehicle weight of around 1000 kg, which is not very significant. But the ability to regenerate energy into the power distribution system is no longer possible. Therefore the vehicle has to either store the energy locally or dissipate it into a brake resistor which must also be carried

in the vehicle [6]. In relation to maintenance costs, Alstom assures that maintenance overcost due to APS is marginal (less than 3%).

Finally, concern exists in relation to the potential for stray currents where the roadway is wet or wet with a salt solution for snow clearing [2]. On the other hand, it is probable that extra care must be taken in the case of extreme-weather cities, for avoiding the contact strip to suffer from ice and salt build-up across the conductors.

2.1.2 Ansaldo's TRAMWAVE system

The TramWave technology is quite similar to APS. Again, the power supply system consists of a 750 V-dc third rail embedded in the permanent way, provided by a contact line that only energizes a small section as the vehicle passes over it.

TramWave is the result of the technical evolution and adaptation to tram vehicles of STREAM (Electric Power System with Magnetic Attraction) system, developed by Ansaldo more than ten years ago, and successfully tested in Trieste's tyre vehicles (Italy), specifically in hybrid buses.

In this case, the basic building block of the TramWave system is a modular unit, 3 or 5 m long, 30 cm wide and 12 cm high, that contains all the elements needed for the correct functioning of the ground-level power supply system.

A series of steel contact plates are located at intervals on the top of the box (see Figure 3). The modular boxes are joined together to form the power supply of the light rail line. The modules are placed in a "continuous conduit" that contains the positive feeder and a negative cable to protect the line.

The power collection is made by means of a retractable pickup shoe placed in the centre of vehicle's truck. It is equipped with hybrid magnets which attract the power element located at the bottom of the module. The power element is flexible, in such a way that it can be elevated and when it is in contact with the top part of the module the ETR segments in contact with the shoe are energized (see Figure 3).

The system is designed in such a way that the energized length is not greater than 1.5 m (three segments at the most), remaining always under the vehicle.

Ansaldo assures that this system has lower maintenance requirements than the OCS, because any breakdown will affect only one module, which is automatically identified by the diagnosis system, and can be replaced by another complete module in barely 30 minutes. In addition, the failure of one module does not prevent the vehicles from running over the track, and the replacement can be made when the line is in service.

TramWave can be commuted from overhead to ground supply, even when the vehicle is moving, either automatically or by the driver's order. In addition, it can be combined with on-board energy storage systems, and the power supply can be used to recharge them. In the same way, the vehicle can be disconnected from the supply line, even when it is moving, and run autonomously with energy stored on-board.

An additional advantage of this system is the fact that the return current is transferred via the contact plates and the tracks do not need to be used for this purpose. This is an important feature since in this way the TramWave eliminates the effects of stray currents, avoiding the need for track electrical isolation.

Finally, this power supply system can also be used by electrical vehicles which have rubber tyres. Consequently, the tramway line equipped with the TramWave system can become the backbone power line for different vehicle fleets and/or a global network that uses it as a mobile charging station for battery-powered vehicles.

The main drawback of this system is that it has not been applied to any real system, although tests for the feeding modules on the Naples (Italy) test track were successfully completed and there is now an actual trial version of the system equipping 600 m of the Naples-Poggioreale experimental line. Therefore, there are not enough data to make conclusions about cost and reliability of the system.

Finally, as for the case of Alstom's APS solution, there is concern as to the potential for stray currents where the roadway is wet or wet with a salt solution for snow clearing [2].

2.1.3 Bombardier's PRIMOVE system

The PRIMOVE system is similar to APS and TramWave in some aspects, as that the wires laid beneath the ground are connected to the power supply network, and are only energized when fully covered by the vehicle.

Nevertheless, the technology for getting the energy from the ETR is very different, as it is based on the inductive power transfer of a transformer (see Figure 4), without contact. While a magnetic field is

generated, energy is stored in the primary electric circuit, that is located between the rails of the track, and the secondary circuit, under the vehicle, transforms this energy field in electric power for tram's operation.

In this case, to get the energy, a pick-up coil underneath the vehicle turns the magnetic field created by the wires in the ground into an electric current that feeds the vehicle's traction system.

This system is able to provide the energy needed for running up to 40 km/h over a 6% ramp.

Additionally, vehicles with PRIMOVE can be provided with the MITRAC energy saver technology by Bombardier (see section 2.2.2).

PRIMOVE is undergoing extensive testing at the test track of the Bombardier site in Bautzen, Germany, simulating regular operation. Additionally, Bombardier announced on May 2010 that PRIMOVE is going to be tested in German Augsburg's line 3 in a test branch 800 m long.

An important advantage of this system in relation to the two previously presented is that there is no direct contact during energy transfer, and therefore, there is no wear of parts and components. This is supposed to keep service and maintenance costs at a minimum.

On the other hand, Bombardier assures that this system is resistant to all weather and ground conditions including storms, snow, ice, sand, rain and water, as well as that it gets the same vehicle performance as with conventional OCS.

The main drawback is, as for the TramWave system, that it has not been tested yet in any real application, although the results of the Augsburg test will be of interest to know more about its performance. Bombardier assures that the initial construction costs lie far below those of any comparable solution on the market, but it can not be contrasted until the Augsburg results are available.

Additionally, depending on the frequency of operation, the magnetic or inductive coupling may also produce some local electromagnetic effects. On the other hand, this system has the same problem as the Alstom's one in which is related to energy regeneration [6].

2.2 Energy storage on-board the vehicle

The main disadvantage of ground power supply is, probably, that like in the case of OCS, it involves the installation of fixed infrastructure, with the corresponding construction and maintenance costs, and the additional problems to provide it to an existing network.

An alternative to these solutions is the use of on-board energy storage systems. These technologies emerged, in the first stage, not in order to avoid the existence of overhead wires, but to improve the energy efficiency of light rail systems.

Indeed, one way to reduce the energy consumption of trams is by using of regenerative braking, which is widely extended in the railroad field, so as to make the most of the kinetics energy that has to be dissipated during the braking process (that is very frequent in cities). But in the initial stages, for regenerative braking to be effective, there had to be other vehicles around to absorb the surplus power being fed back into the OCS, especially when traction is of dc type. Too often, power produced by traction motors in braking mode ended up lost heating resistor banks.

To prevent this from happening, trams started to be provided with on-board energy storage systems, in such a way that braking energy is saved for use when necessary due to points in the vehicle's demand, as is the case of acceleration. But very soon, the technicians were conscious of the additional possibilities of this kind of technology to avoid the use of overhead wires in specific branches of the network.

The most common technologies of on-board energy storage systems are batteries and, most recently, super-capacitors. Other systems, as flywheels, have been used in some vehicles but they do not seem to be a solid option. It can be due to the risk implied by having high speed rotating machinery in close proximity with passengers, as well as to the flywheel's concentrated weight and inertia. In any case, perhaps further study of flywheels might be warranted because of their excellent charge/discharge cycle life, even though they have not so far seen recent service acceptance comparable to batteries or super-capacitors.

It must be highlighted that the vehicle which has an on-board energy storage system is able to run even when it experiences poor contact on the wires, due, for example, to ice formation, maintaining speed until electrical contact can be regained. On the other hand, the zones without overhead wires are obtained without need for extra installations or special investments.

A comparison between different on-board energy storage devices is made in Table 1.

2.2.1 Batteries

Battery storage is a proven and mature technology. It provides a relatively good weight-to-power ratio and low cost. One of its major disadvantages is that the battery is affected by temperature, which at low temperatures results in loss of capacity, and at high temperatures can cause plate buckling leading to short circuits and loss of voltage, or even electrical fires in extreme cases. Batteries are susceptible to rapid charge cycles and deep discharges, which can result in some loss of life expectancy and overall performance. A further disadvantage is that most batteries require routine maintenance and inspection and also regular charge and discharge cycles to maintain peak performance [6].

Nevertheless, the rapid development of Nickel-metal hydride batteries (NiMH) in recent years has allowed several tram manufacturers to offer an alternative to both overhead and ground power supply.

In November 2007, Nice became the first city in France to use battery-powered Alstom Citadis vehicles. Each vehicle is equipped with roof-mounted NiMH batteries which are charged from the OCS and allow the vehicles to run through two historic squares where OCS has not been installed. The batteries allow the vehicle to operate at up to 30 km/h, albeit with a lower rate of acceleration than OCS [5].

Alstom, CAF, and other manufacturers are also investigating the potential of lithium-ion (Li-Ion) batteries, which offer higher density energy storage than the NiMH cells, and which are having an important development due to automotive industry.

As another example of battery use, Kawasaki has been testing its Swimo OCS-free vehicles in the Japanese city of Sapporo [7]. Swimo uses Kawasaki Gigacell NiMH batteries, which can be fully charged in five minutes through the 600V-dc OCS. This allows Swimo to operate for up to 10 km on non-electrified lines under standard Japanese operating conditions, although Kawasaki has run the vehicle for 37.5 km during tests without recharging the battery. Swimo can also store energy from regenerative braking and use it for traction [5].

Nevertheless, although NiMH batteries have the necessary energy storage density in terms of kWh/kg, it seems to be generally accepted that their life in terms of charge/discharge cycles in no way matches the light rail vehicle's requirement for 2 million cycles over 10 years [8]. On the other hand, Li-Ion batteries technology seems to be in a very initial stage of research for their use in transit applications. This is the reason that is leading to the imposition of super-capacitors instead of batteries. In any case, it will be worthy to follow future developments in this field, given by automotive industry, and check their applicability to transit systems.

2.2.2 Super-capacitors

Super-capacitors are an improved and more challenging version of capacitors for transit applications. In a conventional capacitor, energy is stored by removing electrons from a metal plate and depositing them on another. This charge separation between the two plates can then be harnessed in an external circuit. The amount of charge stored is a function of the size and material properties of the plates, while the flow of energy between the plates is dictated by the composition of the dielectric. By sandwiching different materials between the plates, different voltages can be stored [5]. In any case, the capacity of conventional capacitors is really low, and is not suitable to match the requirements of transit vehicles.

Super-capacitors do not have a conventional dielectric. Rather than two plates separated by an intervening substance, these capacitors use plates that are in fact two layers of the same substrate, and their electrical properties, the so-called electrical double layer, result in the effective separation of charge despite the vanishingly thin (on the order of nanometers) physical separation of the layers. The lack of need for a bulky layer of dielectric permits the packing of plates with a much larger surface area into a given size, resulting in extraordinarily high capacitances in practical-sized packages.

The storage capacity of double-layer capacitors can be improved by using a nanoporous material such as activated carbon. A single gram of activated carbon has the same surface area as half a soccer pitch [9].

The advantage of the super-capacitor is that it has a high charge/discharge rate and can absorb the immediate energy produced by braking energy regeneration. Its low equivalent series resistance means that power loss in the device is small and the units can run at typically 95% efficiency. Furthermore, super-capacitors can be completely discharged without reducing their service life, and extreme temperatures have very little impact on their performance [6, 9].

In the last years, several trams provided with super-capacitors have been developed by manufacturers. These solutions imply an increase in vehicle weight and cost, but it is compensated by energy savings in general cases.

Alstom's STEEM solution

Alstom has developed its STEEM (Maximal Energy Efficiency Tramway System), which is being tested on line T3 in Paris (France). An Alstom Citadis vehicle has been fitted with a 1.4 tonne roof-mounted unit housing 48 super-capacitor modules. These modules can be completely charged in 20 seconds through the overhead system or a charging station, and can also take charge from the regenerative braking system [9].

The test vehicle is capable of travelling 300 m with 300 passengers on board at up to 23 km/h, with 30% of the power remaining when it reaches the next stop. However, Alstom says that it is possible to mount a second Steem unit on the roof of a Citadis to increase the range of OCS-free operation. The super-capacitors can still take energy from the regenerative braking system, even when the vehicle is drawing traction power from the Steem module [9].

Bombardier's MITRAC solution

Bombardier has developed the MITRAC system, based on the super-capacitors technology, and made a demonstration trial in the Manheim network (Germany), which has been in normal service since 2003 [8].

This vehicle has two powered trucks, each with two motors. One of them has been equipped with a MITRAC unit, while the other is supplied conventionally so that the energy performance of the two halves of the tram can be compared. Energy savings of around 30% were demonstrated by the MITRAC half of the vehicle for most of the year, compared to its conventional twin [8].

MITRAC weighs about 450 kg, and the external dimensions are 1900 mm long, 950 mm wide and 455 mm deep [8].

The vehicle provided with the MITRAC unit was consistently able to travel through a simulated 500 m gap reaching speeds up to 26 km/h with the pantograph lowered, despite the fact that it has only one MITRAC unit fitted rather than a normal pair [8].

CAF's ACR solution

CAF (Construcción y Auxiliar de Ferrocarriles) has been developing its ACR (Rapid Charge Accumulator) OCS-free system in conjunction with Trainelec and Aragon Technical Institute [5].

The super-capacitors can be fully charged, while the train is stopped in a station, in around 20 seconds [5]. In addition, as for the rest of technologies, the system recovers the energy stored on the journey and the braking energy too [10].

The roof-mounted accumulator is suitable for rolling stock of any manufacturer, as well as any new or existing installations or infrastructure [10]. It can be complemented with NiMH batteries as back-up for solving super-capacitor's failure situations.

The implementation of ACR in a light rail vehicle increases its weight around 2 t per module. With the common solution for OCR-free systems of two modules, this leads to an increase of 4 t. The increase of weight is compensated with the energy saving.

The system has been tested during one year, in a first stage in Vélez-Málaga, and in May 2010, the first tram provided with ACR initiated its commercial service in Seville (Spain). These vehicles will allow the OCS to be definitely eliminated in the whole Seville network but at stations [11].

CAF assures that these vehicles can achieve a maximum autonomy of 1000 m, but in the commercial service 500 m are guaranteed with active auxiliary systems [11].

In relation to vehicle's overcost due to super-capacitor provision, CAF assures that in the next developments it can be around 10-15%. Super-capacitor's life depends on temperatures and charge/uncharge cycles. For Seville, this life is expected to be around 7-8 years.

An illustration of ACR's performance is presented in Figure 5.

Siemen's Sitras HES solution

The Siemen's Sitras-HES solution consists of two energy storage devices: the Sitras-MES (super-capacitor mobile energy storage unit) and a NiMH battery. This concept combines, as CAF's ACR, the benefits of the super-capacitors with the characteristics of a traction battery. The capacitors recharge faster and deliver the energy faster than traction batteries, which release their stored energy over longer periods.

The roof-mounted modules have been installed in spare roof space on a Siemens Combino Plus vehicle, and are electrically connected to the vehicle's energy supply point. This means that Sitras can be easily retrofitted to older vehicles, including those of other manufacturers [5].

Sitras-HES can complete its charging cycle in 20 seconds, taking power from the catenary or a charging point while the vehicle is standing in a station. This provides sufficient power for the vehicle to run independently for up to 2.5 km, depending on the operating conditions [5].

Siemens began work on this system in September 2007, and it has been used on Lisbon's Metro South light rail network (Portugal) since November 2008. Indeed, the Sitras-HES is being successfully

used in everyday passenger transport operation. The test vehicle is operated without overhead power supply on a 2.6% gradient with auxiliary power of 5 kW and a maximum speed of 30 km/h [5].

In Germany Sitras has also been approved for use in public passenger transportation, in accordance with BOStrab (a legal ordinance governing the manufacture and operation of streetcars) [5].

2.3 Electric energy produced on-board the vehicle

There are different possibilities to generate electric energy on-board the trams. They are, basically, fuel systems such as hydrogen fuel-cells, hydrogen internal combustion engines, and diesel-electric generator sets.

The hydrogen-based systems have not been yet advanced to a point where they can be applied to a transit vehicle for commercial application. Fuel-cell technology continues to be developed along with the infrastructure required for hydrogen fuel-cells (storage tanks and pumping equipment for refueling the vehicles), and while it seems to be a promising technology, it is not still mature enough. Finally, diesel-electric generator sets have been used in various applications in the world, but the industry is moving away from fossil fuel based systems [2].

Therefore, this third range of solutions does not seem to be a good option for avoiding the use of OCS wires in a short-term future.

3 CONCLUSIONS

The only solution that can absolutely avoid the use of OCS wires in the whole network is the ETR. Among the different available technologies, some of them have a high degree of development and testing, and others are more in the testing stage. In general, they are capital cost intensive, it is supposed that they will have higher operation and maintenance costs and they will require more substantial safety certification [2]. In some of them, it is necessary to assure the prevention of stray current problems under some environmental conditions.

On the other hand, an additional concern can be related to the proprietary nature of the technology and the potential to become dependent on a single supplier.

In general, it must be highlighted that the implementation of the ETR technology in all or part of the network will represent an increase in the construction costs, although the statement from section 2.1.1 relating to the entailed percentage of total costs can be applied to every one of the existing technologies.

In a near future, it is possible that manufacturers will be able to keep the promise made to be nearly cost neutral, and may some day even prove more cost-effective, but this is not the case today.

On the contrary, the technology that is more developed and more cost-effective nowadays is the use of batteries/super-capacitors or a combination of them for energy storage in the vehicle. The storage devices capture and hold energy, both from regenerative braking, from OCS wires where they are provided, and from charging stations, and use it where the OCS is not available. The size and weight of the energy storage device will be related to the amount of energy to store, and so, to the layout of the track and the vehicle's weight.

For these solutions, attention must be drawn to charging times, independence range, and maximum power allowed by the system.

These solutions have the additional advantage that they can be mounted in old vehicles and in the ones supplied by manufacturers that do not have this kind of technology. So, they are not so penalized by proprietary problems.

In general, it is important to note that the equipment that is not service proven can result in costly failures, train service delays, traffic disruptions, retrofits, equipment damage, or even employee or passenger injury. Nevertheless, proven-technologies are emerging that will be able to avoid overhead wires at least in the more sensitive areas of cities. This new advance can be the fact that propels the implementation of light rail networks in some reticent communities.

ACKNOWLEDGEMENTS

The author thanks the collaborations of cited manufacturers for their contribution with documentation about their systems.

REFERENCES

1. Vuchic, V.R. *Urban Transit Systems and Technology*. John Wiley & Sons Inc., New York, 2007. ISBN: 978-0-471-75823-5.

2. URS Corporation. *Streetcar Technology Assessment*. City of Charlotte Engineering & Property Management, Charlotte, North Carolina, May 2010.
3. Boorse, J.W. Directly and Indirectly Reducing Visual Impact of Electric Railway Overhead Contact Systems. In *Transportation Research Record: Journal of the Transportation Research Board*, No. 1930, Transportation Research Board of the National Academies, Washington, D.C., 2005, pp. 57-61.
4. Boorse, J.W. Dual-Mode Traction Power Distribution for Light Rail Transit. A Design Option. In *Transportation Research Record: Journal of the Transportation Research Board*, No. 1677, Transportation Research Board of the National Academies, Washington, D.C., 1999, pp. 67-72.
5. Barrow, K. Wireless connections. *International Railway Journal*, Simmons-Boardman Publishing Corporation, Cornwall, United Kingdom, June 2009.
6. City of Ottawa. *Power collection and distribution systems*. On-line available: http://www.ottawa.ca/residents/public_consult/tmp/lrt/discussion_papers/power_collect_en.html. Access on July 2010.
7. IRJ. Kawasaki Heavy Industries, Japan, could offer considerable savings in energy and infrastructure costs. *International Railway Journal*, Simmons-Boardman Publishing Corporation, Cornwall, United Kingdom, August 2008.
8. Hope, R. UltraCaps win out in energy storage. *Railway Gazette International*, DVV Media UK Ltd., July 2006.
9. Barrow, K. Power to the people: the development of supercapacitors has spawned a flurry of 'energy tank' systems from LRV manufacturers. *International Railway Journal*, Simmons-Boardman Publishing Corporation, Cornwall, United Kingdom, September 2009.
10. Thomas, G. The CAF Rapid Charge Accumulator: Technology for Removing Catenary Between Stations, *Tecnirail*, Montané Comunicación S.L., Madrid, Spain, June 2009.
11. Rodríguez, A. Tranvía sin catenaria desarrollado por CAF y basado en el empleo de ultracondensadores. *Vía Libre*, Fundación de los Ferrocarriles Españoles, Madrid, Spain, February 2009.

TABLE INDEX

Table 1: “Comparison between on-board energy storage devices”. Source: Modified from [6].

FIGURE INDEX

Figure 1: “a) Overhead contact wires in Tenerife’s light rail network (Spain). b) Miami’s street with electric wires close-up”.

Figure 2: “Alstom’s APS solution. a) General diagram. b) ETR detail”.

Figure 3: “Ansaldo’s TramWave system. a) ETR. b) Pick-up shoe. c) Diagram of pick-up process”.

Figure 4: “Bombardier’s PRIMOVE system. a) Technology base. b) Vehicle’s diagram”.

Figure 5: “CAF’s APR technology. a) LRV without ACR running under OCS. b) LRV without ACR braking. c) LRV with ACR running without OCS. d) LRV with ACR braking and accumulating energy in ACR modules. e) LRV with ACR accumulating energy in a zone with OCS”.

TABLE 1 Comparison between on-board energy storage devices. Source: Modified from [6]

STORAGE SYSTEM	Rate of charge	Life cycle cost	Life expectancy	Cost/Power storage	Power density/Weight	Safety
Super-capacitor	Very short charge	Medium	High	High	6 kWh/kg	High
Flywheel	Short charge time	Medium	Unknown	High	? (low)	Low – Not proved
Battery	Long charge time	Medium	Limited life	Low	30-160 kWh/kg	High



FIGURE 1 a) Overhead contact wires in Tenerife's light rail network (Spain). b) Miami's street with electric wires close-up.

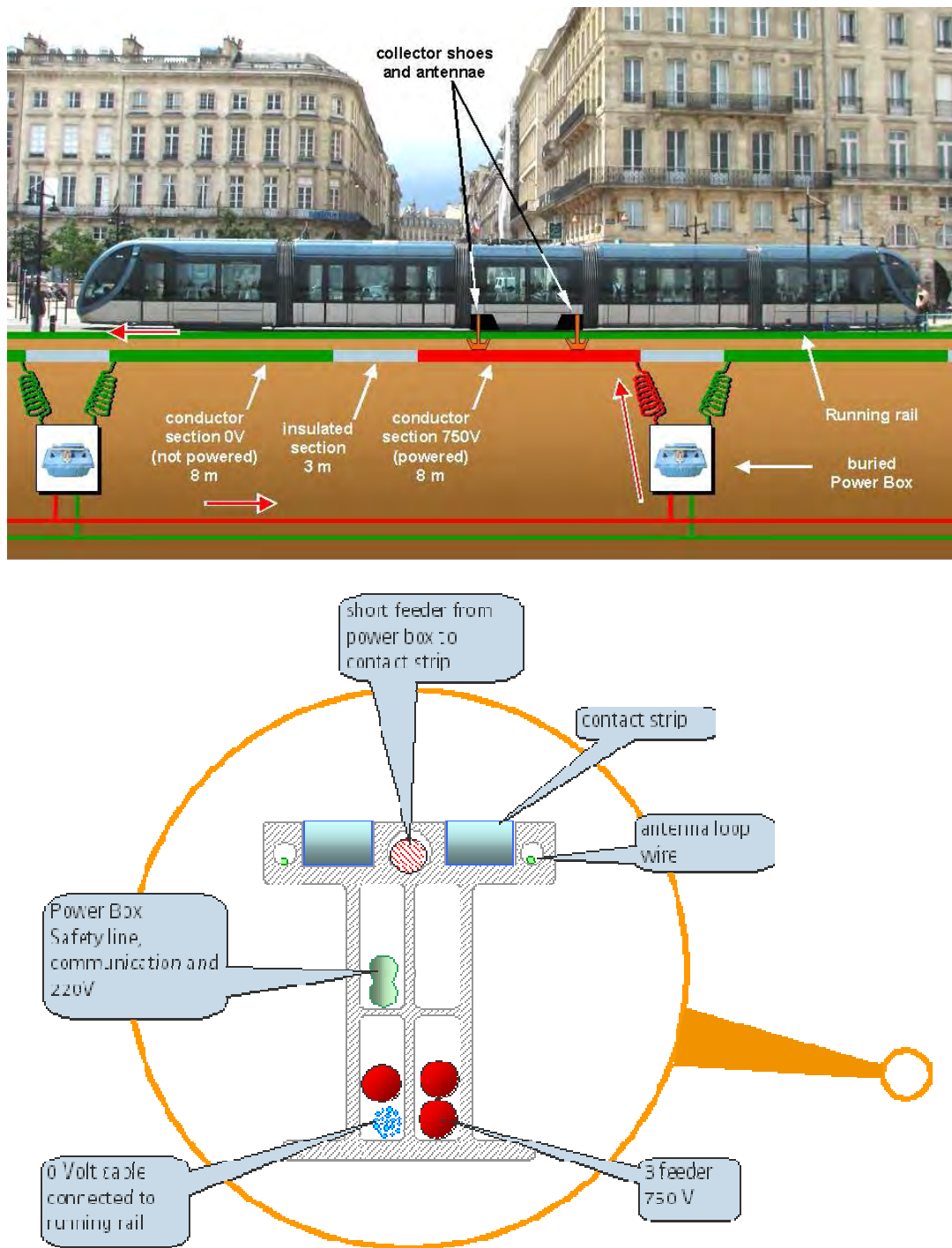

FIGURE 2 Alstom's APS solution. a) General diagram. b) ETR detail. Courtesy of Alstom.

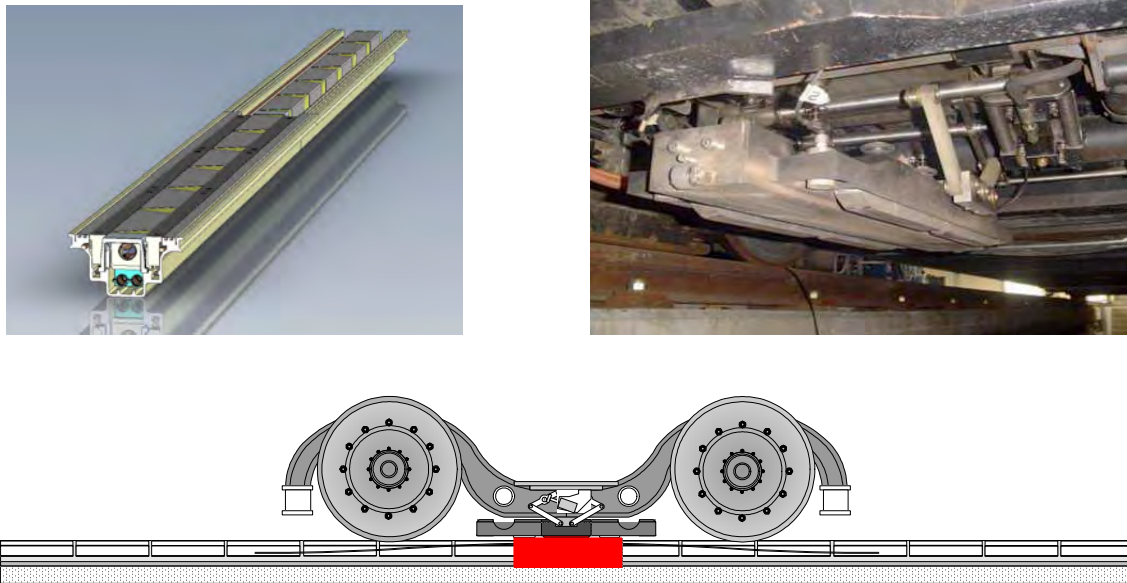

FIGURE 3 Ansaldo's TramWave system. a) ETR. b) Pick-up shoe. c) Diagram of pick-up process.
Courtesy of Ansaldo.

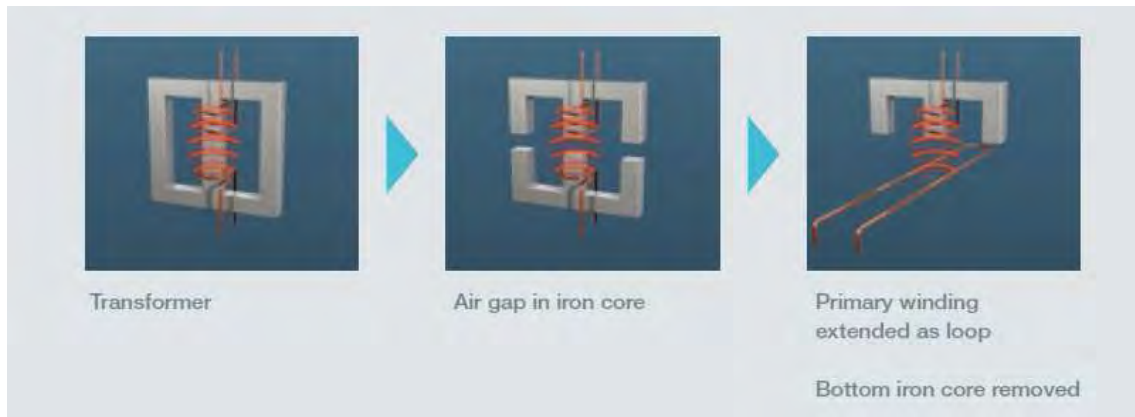

FIGURE 4 Bombardier's PRIMOVE system. a) Technology base. b) Vehicle's diagram. Courtesy of Bombardier.

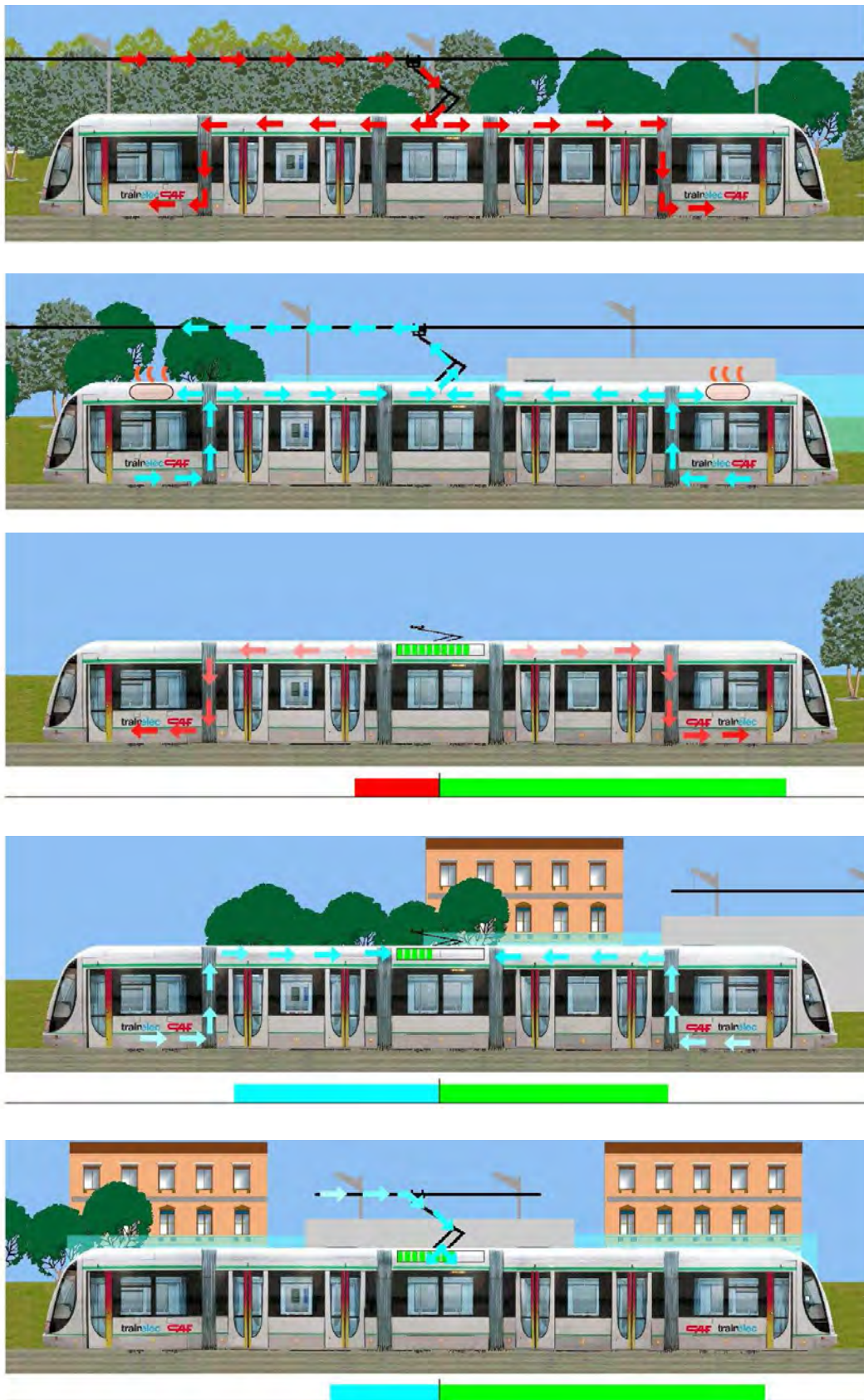

FIGURE 5 CAF's APR technology. a) LRV without ACR running under OCS. b) LRV without ACR braking. c) LRV with ACR running without OCS. d) LRV with ACR braking and accumulating energy in ACR modules. e) LRV with ACR accumulating energy in a zone with OCS. Courtesy of CAF.

Streetcar Propulsion Power: Alternatives and Considerations

APTA Streetcar and Heritage Trolley Subcommittee

James H. Graebner, Chair

T.R. Hickey, AICP, Vice Chair

Timothy R. Borchers, Secretary / Technologist

James D. Schantz, Communications / History

Martin P. Schroeder, P.E., Chief Engineer, APTA

Public Meeting

Hosted by: DC Surface Transit, Inc.

Renaissance Hotel

Washington, DC

May 6, 2010



*American Public Transportation
Association*

Introduction:

American Public Transportation Association

- Leading Force in Advancing Public Transportation Since 1882
- Legislation
- Conferences – Over 20 a year
- Education and Training
- Committee Activities
- Standards Development
- Data Collection and Dissemination
- Scientific Research

APTA's Approach

- Neutral
- Apply Industry Experience
- Utilize our Experts within the Streetcar Subcommittee
 - James H. Graebner, Chair
 - Thomas Hickey, Vice Chair
 - Tim Borchers, Secretary & Technology
 - James Schantz, History and Data

Presentation Outline

- Streetcar Overview
- Conventional Power Systems
- Alternative Power Systems
- Energy Storage Technology
- Implementation and Operation
- Summary

Streetcar Overview

James H. Graebner

Chair, APTA Streetcar and Heritage Trolley Subcommittee
President, Lomarado Group
Denver, Colorado



DC Streetcars

- 1862 – 1962
Streetcar Era
- 1888 – 1895
Technology
Turmoil



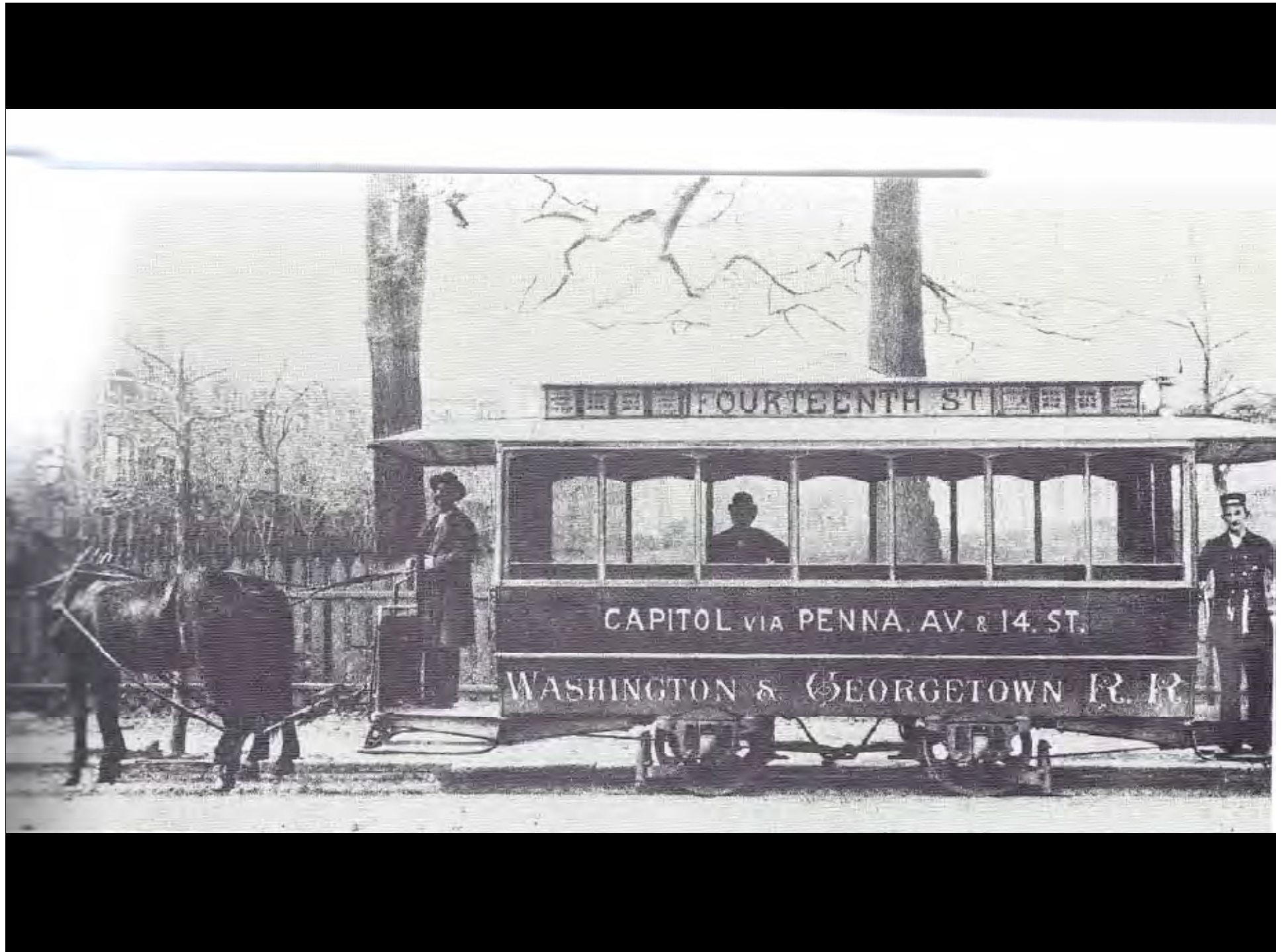



INSULATOR MANHOLE

INSULATOR MANHOLE
FRAME CASTING

TIE ROD TO SLOT RAIL

SLOT RAIL 7"

PLOW
SLOT

BOLTS -
SLOT RAIL
TO YOKE

CONCRETE PAVING BASE

SURFACE PAVING

INSULATOR CASTING

PORCELAIN INSULATOR

INSULATOR STEM

CONDUCTOR BAR
FASTENINGS

CONDUCTOR BONDS

CONDUCTOR BAR
POSITIVE

CONDUCTOR BAR
NEGATIVE

FASTENINGS TO THE
YOKES

RUNNING RAIL WITH
FLANGEWAY

CAST IRON YOKE

CONCRETE ENCASING
THE YOKE

18" X 18" CONCRETE
CONDUIT

CONCRETE FORMING
INSULATION MANHOLE

TYPICAL SECTION
PERSPECTIVE
CONDUIT TRACK

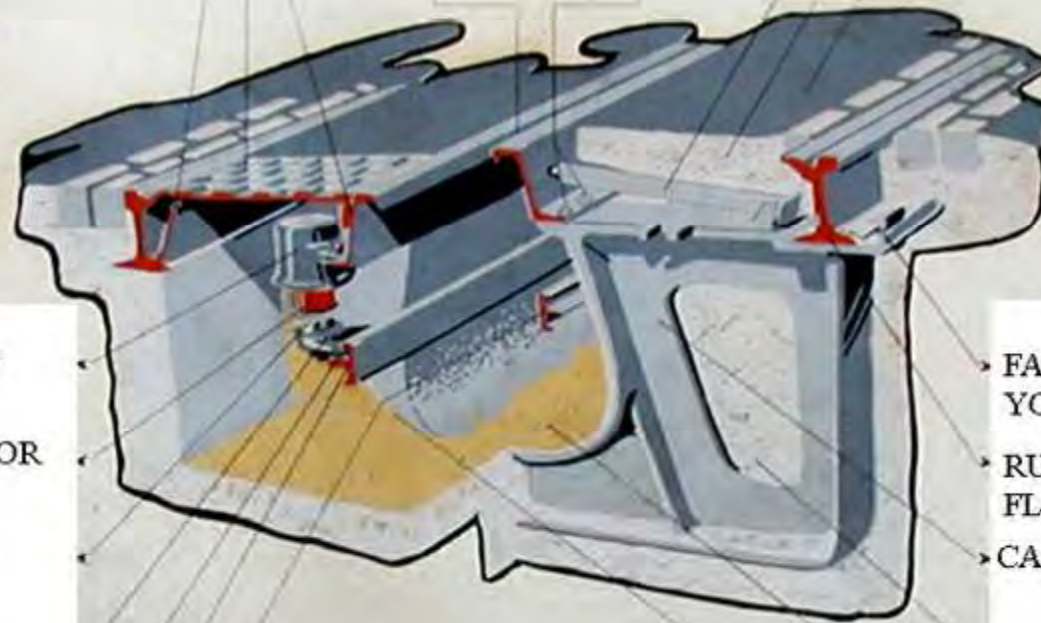





DC Streetcars – *Then and Now*



The fundamentals remain the same despite outward changes in appearance and upgrades in technology.



Streetcar Power Systems

- External power supply or generated on-board
- Continuous or not
 - If not continuous, on-board storage system is needed



*Which approach (or combination of approaches)
best suits the needs of the District?*

Conventional Power Systems

James D. Schantz

APTA Streetcar and Heritage Trolley Subcommittee
Chairman, Board of Trustees
New England Electric Railway Historical Society
Kennebunkport, Maine

19th Century: Experimentation



19th Century: Success

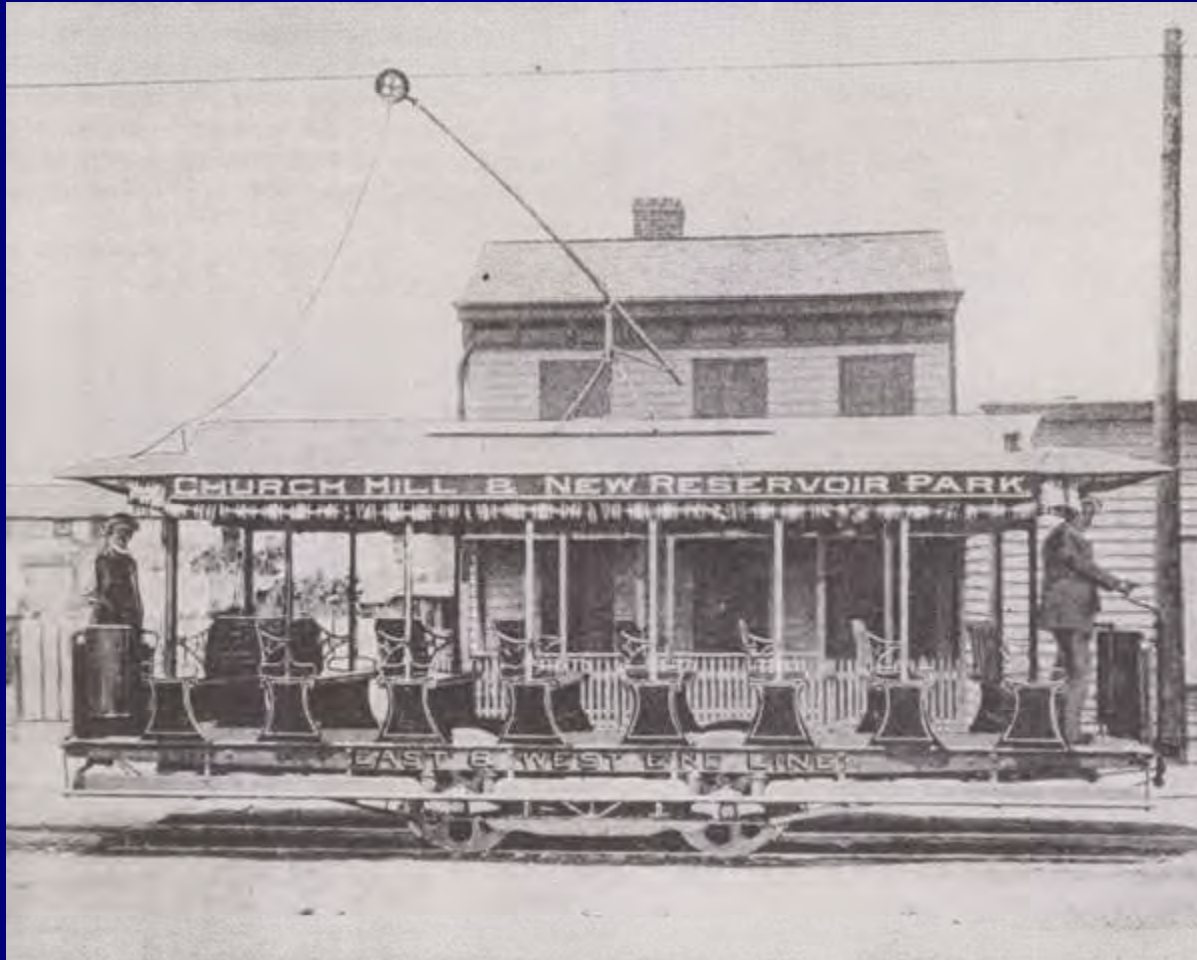

20th Century: Standard Practice



Trolley Wire: What is is *not*...



Trolley Wire: What it is *not*...



Trolley Wire: What it *is*...



Trolley Wire: Poles and Spans



Trolley Wire: Poles and Spans



Trolley Wire: Building Anchor



Trolley Wire: Building Anchor



Trolley Wire: Building Anchor



Trolley Wire: Bracket Arm



Trolley Wire: Bracket Arm



Trolley Wire: Curves



Trolley Wire: Curves



Trolley Wire: Summary

- Used for 120 years around the world
- Inexpensive to build and maintain
- Half inch diameter, 18 feet up
- Visual intrusion can be minimized

Conduit: Only Widely Used Alternative



Conduit: Only Widely Used Alternative



Alternative Power Systems

Timothy R. Borchers

APTA Streetcar and Heritage Trolley Subcommittee
Principal, City Rail Solutions
Tampa, Florida



Alternatives to Overhead Contact System (OCS)

- Ground level power supply.
- On-board electric energy storage (batteries, flywheels, super or ultra capacitors)
- On-board electric energy generation (internal combustion engine, fuel cell)

*Ground Level Power Supply Innorail/APS



Ground Level Power Supply Innorail/APS

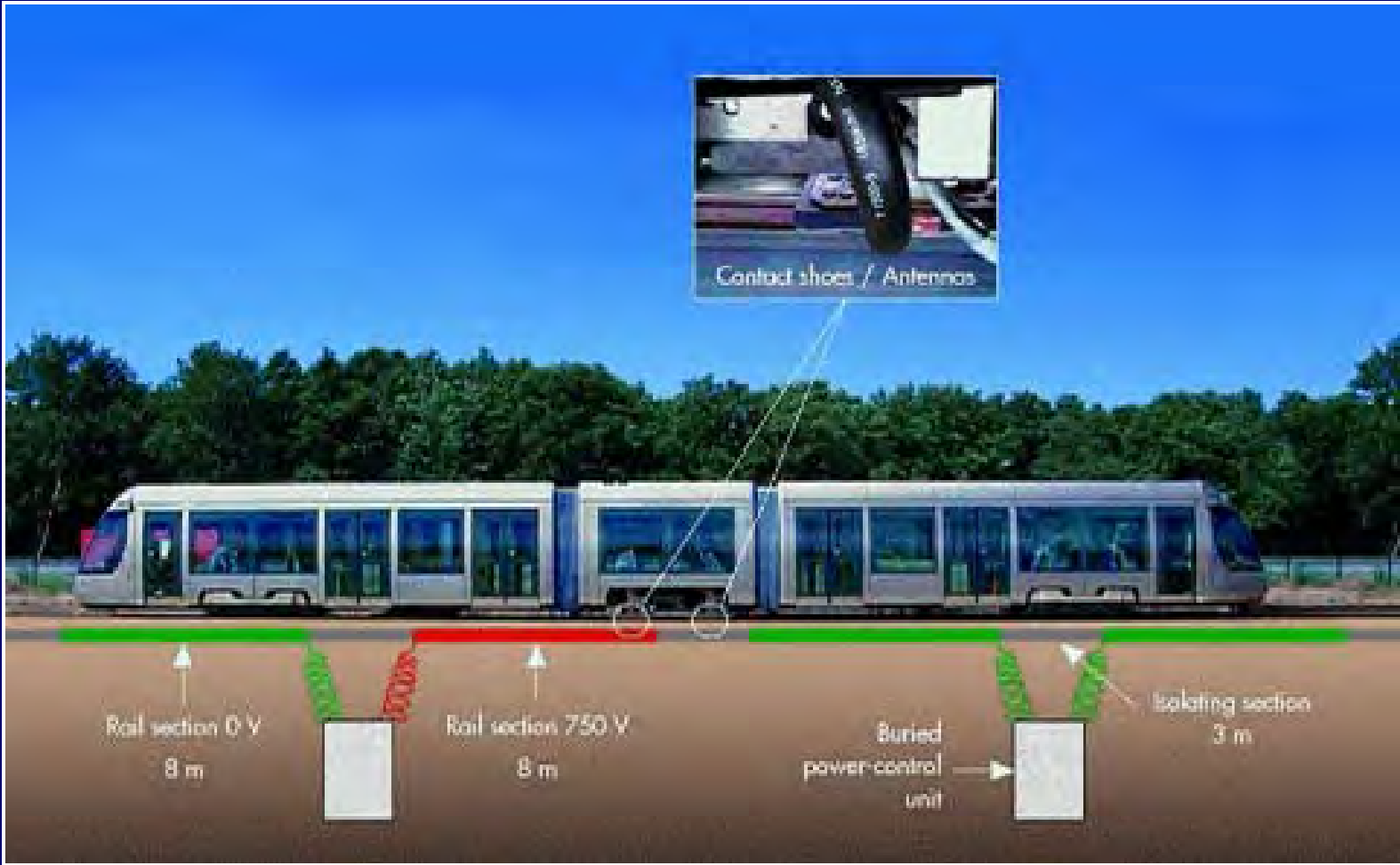

Ground Level Power Supply Innorail/APS

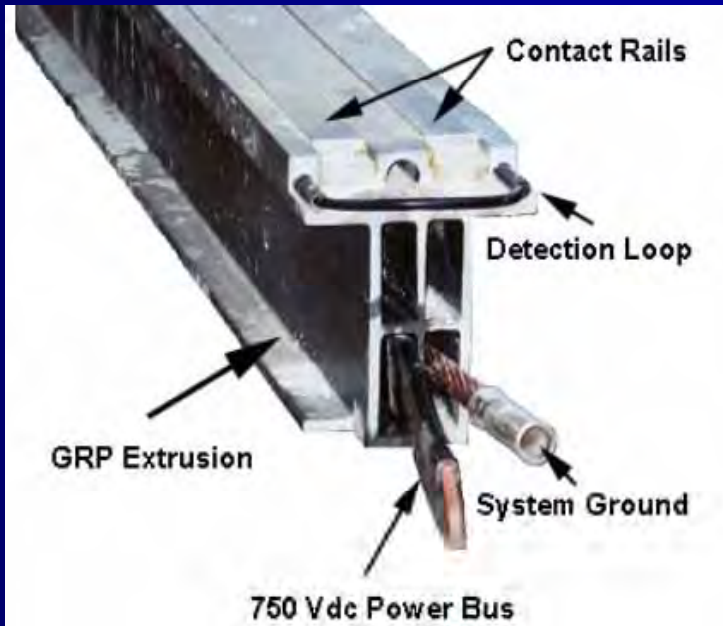

The system had a number of “teething” problems, poor drainage and debris on the contact strips caused service unreliability. Reliability has improved and one kilometer of surface contact replaced with OCS. Reliability under heavy ice and snow conditions has not been established.

Ground Level Power Supply Innorail/APS



Ground Level Power Supply Innorail/APS





Ground Level Power Supply Innorail/APS

- Sources suggest that in Europe APS adds about US \$130,000 to the cost of each tram, while the infrastructure is about 300% more expensive than overhead wires.
- Several new French and European tram systems will use APS over part of their networks.
- The planned Al Sufouh Tramway in Dubai will use APS exclusively.

*Ground Level Power Supply - Primove

Primove was unveiled by Bombardier on Jan. 2 2009.

It uses a magnetic field to transmit power from a circuit built into the track to pick-up coils beneath a tram.

These coils transform the magnetic energy into electricity which charges super capacitors on the tram.

The in-ground equipment is energized only when covered by the vehicle. The prototype provided sufficient power for a 98-ft.-long (30 meter) LRV operating at 25 mph (40 kph) on a six-percent grade.

Bombardier Primove market-ready in 2010.

Ground Level Power Supply - Primove

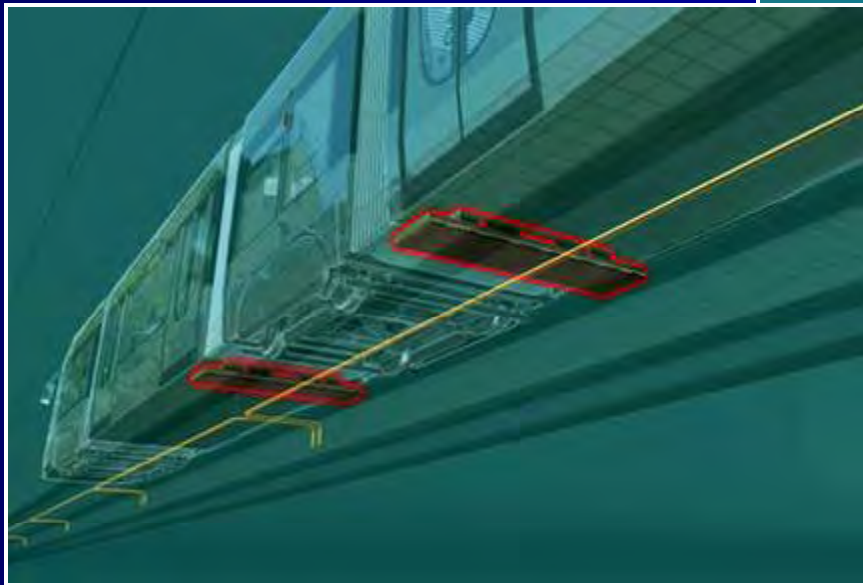
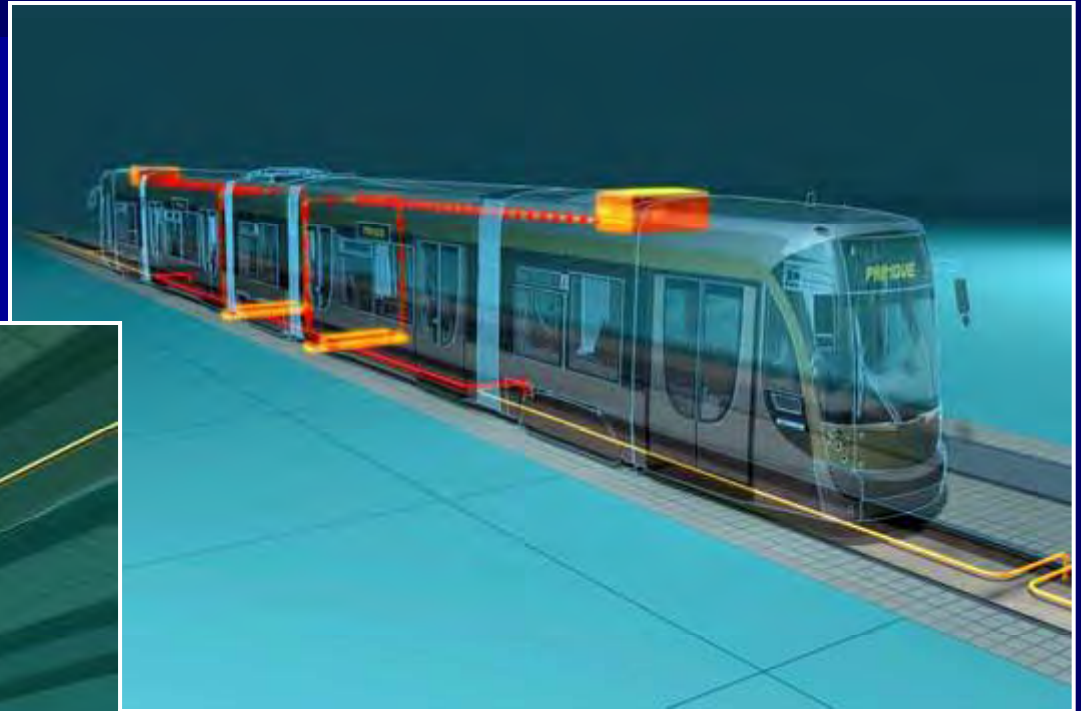

Using inductive power to charge super capacitors to power the tram.

On-board electric energy storage (batteries, flywheels, super capacitors)

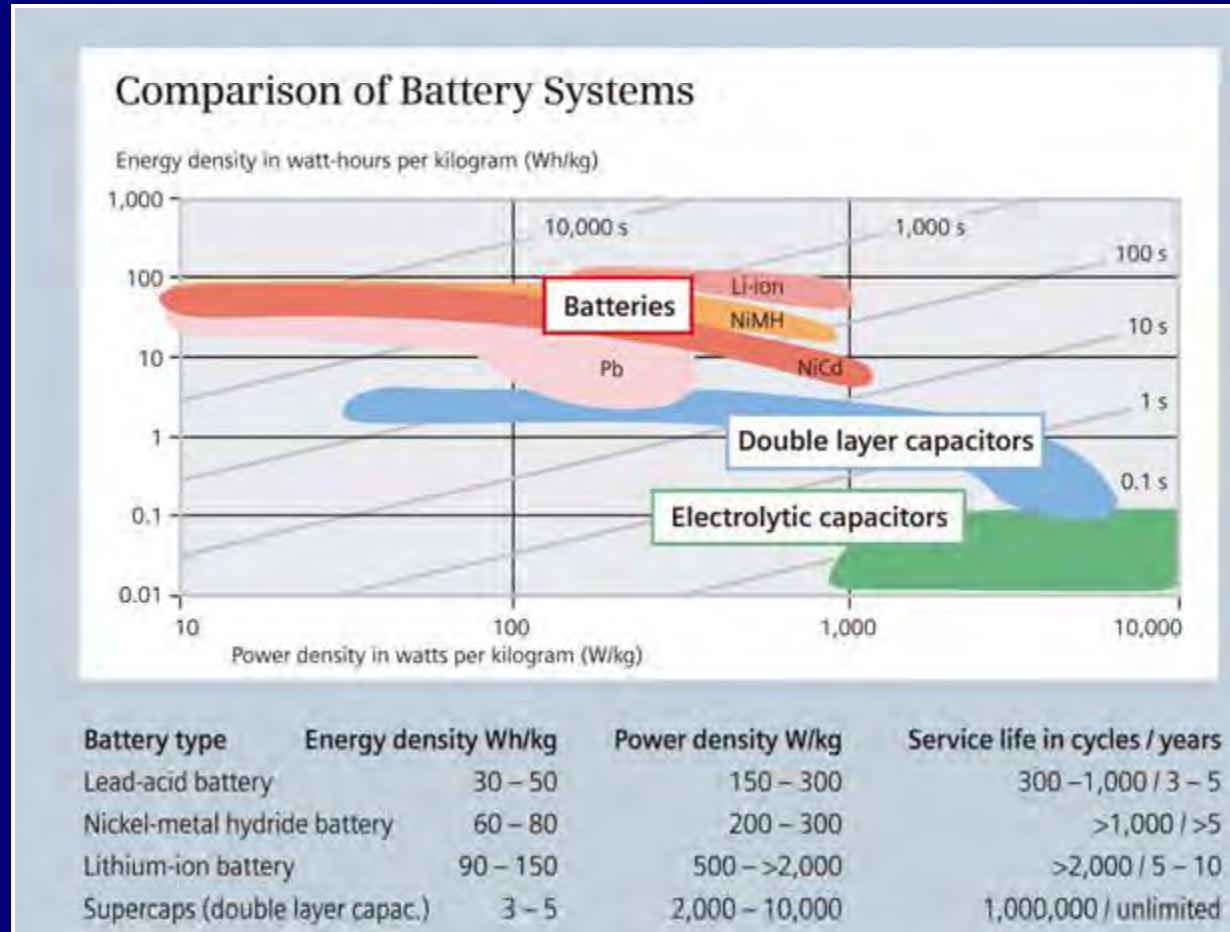

*On-board electric energy storage batteries - Trio Streetcar

Skoda, Inekon and United Streetcar Trio type streetcars may operate wireless in the maintenance facility or through an intersection in the case of OCS power failure.

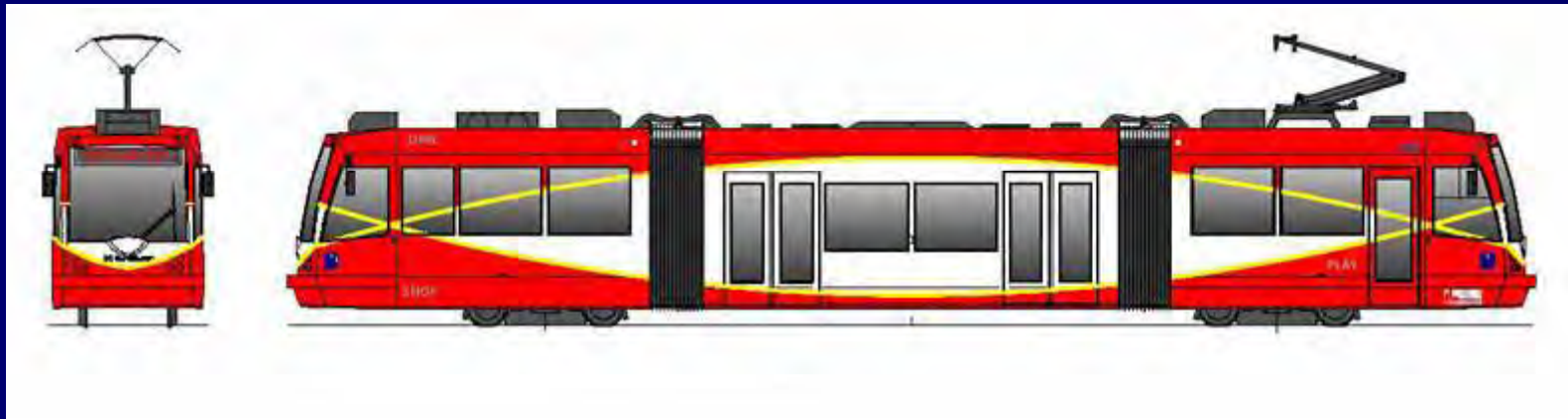

*On-board electric energy storage batteries – Nice France

Nice France

- Opened early 2007
- System Length 8.7 km (5.4 mi)
- Alstom Citadis with batteries
- 20 trainsets
- Daily Ridership 70,000



On-board electric energy storage batteries

– Nice France

- No OCS on 2 squares , Place Massena (435 m) & Place Garibaldi (485 m).
- Use of roof- fitted NiMH (nickel-metal hydride) batteries capable of providing up to 1km of travel at 30km/h.

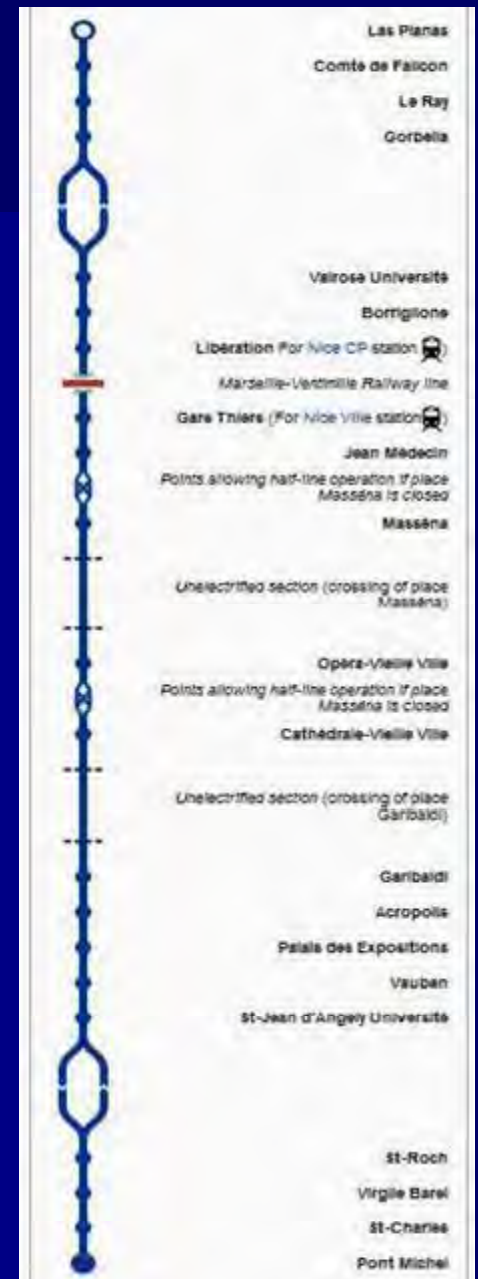

*On-board electric energy storage batteries – SWIMO Battery Tram

Kawasaki SWIMO Battery Car, can operate for 10 kilometers (6 miles) on a single charge of 5 minutes.

In trials, the best performance was 37.5km without re-charging. Between December 2007 and March 2008, trial runs were undertaken in Sapporo City Japan.

Onboard batteries are nickel-metal hydride.



On-board electric energy storage batteries – SWIMO Battery Tram

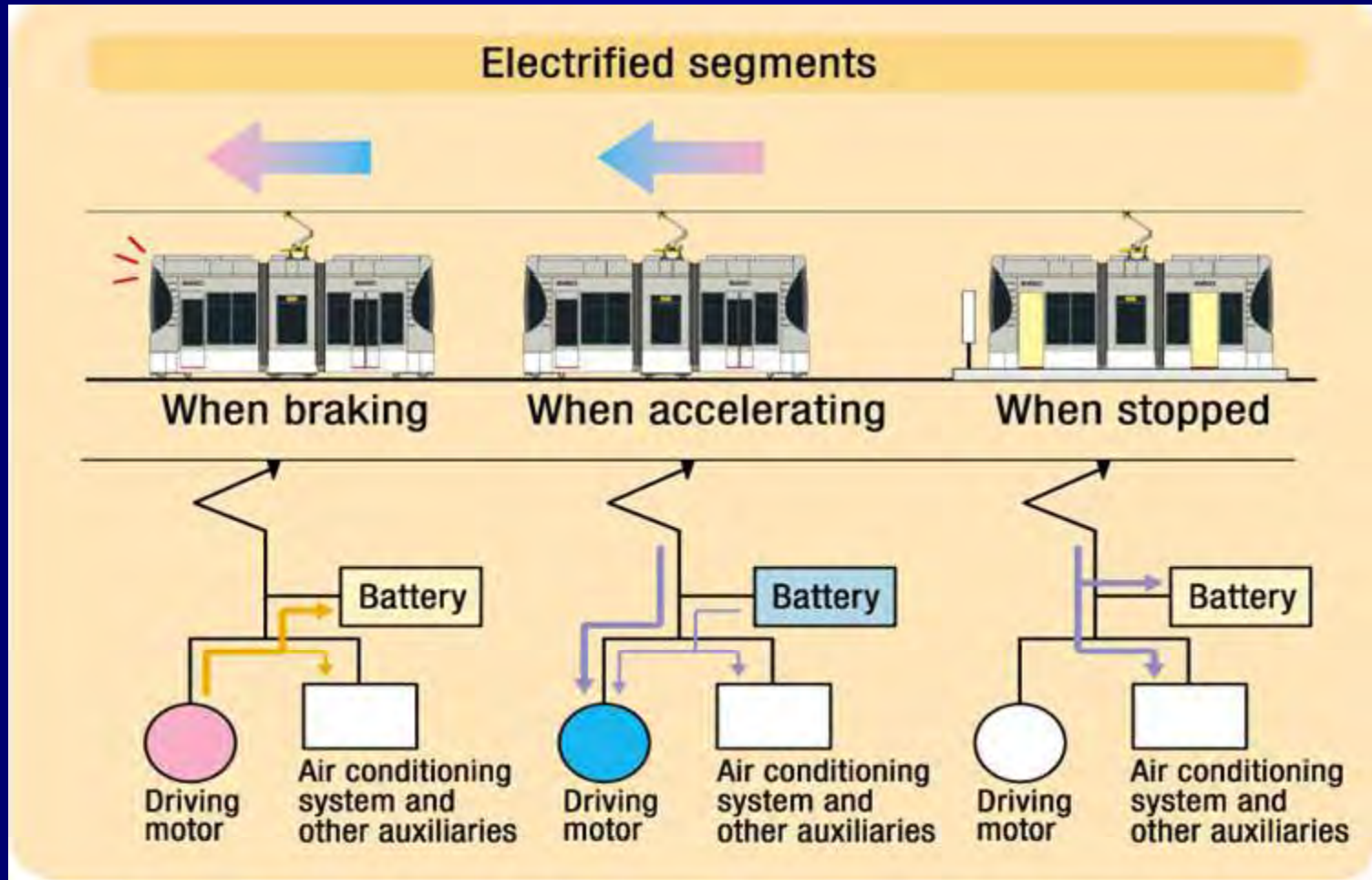

On-board electric energy storage batteries – SWIMO Battery Tram

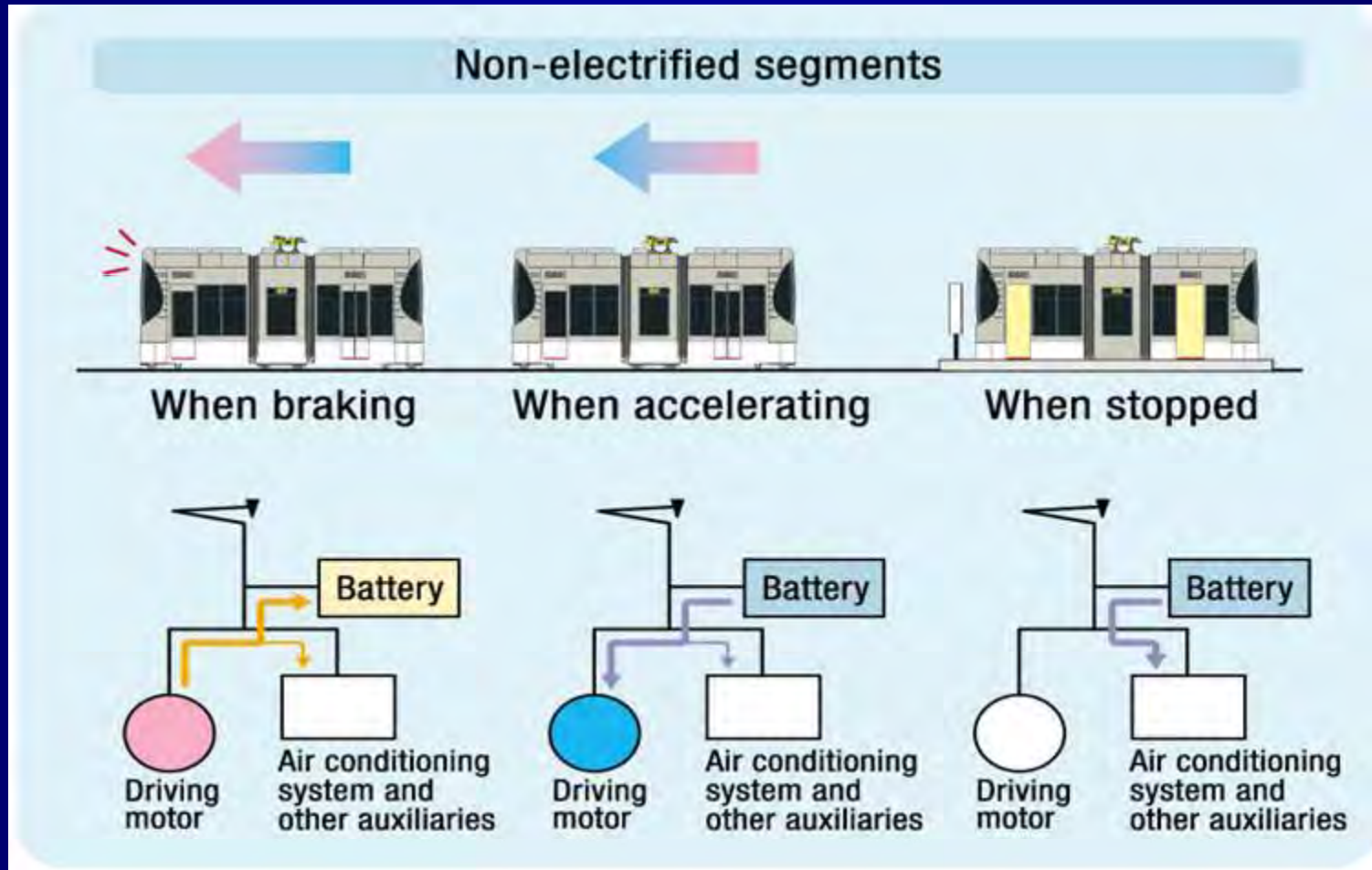

*On-board electric energy storage flywheel.

In Rotterdam, the Netherlands, Alstom the flywheel. It stores kinetic energy from braking and can be re-loaded on sections with OCS to again deliver energy over an OCS section of up to 2 kilometers at 50 kph.



On-board electric energy storage flywheel.

A carbon fibred rotating permanent magnet motor-generator located on the roof of the tram works on the same principle as a spinning top.

The kinetic energy stored during braking is restored by the electric generator is returned to the propulsion system when the tram accelerates.

The system is recharged each time the brakes are applied or by a complementary high-speed recharging system each time the tramway stops at a station.



*Power Systems – Storage Capacitors

- Theory behind electrochemical (EC) or double layer capacitors (DLC) known for over 100 years, not until the 1960s was developed as a functional energy storage device.
- Known also as Super or Ultra Capacitors.
- Super capacitors or Ultra capacitors used by the US military to start the engines of tanks and submarines.

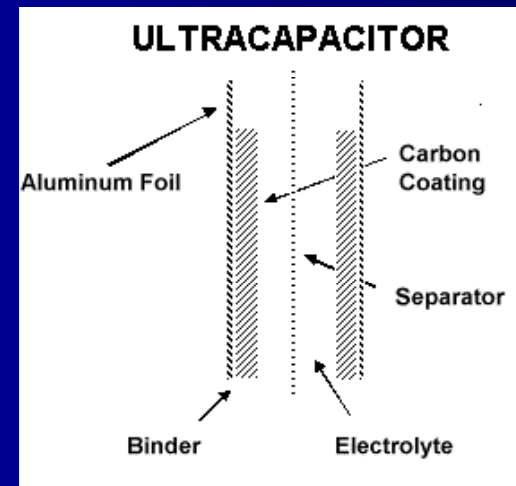

On-board electric energy storage super or ultra capacitors.



Banks of Supercaps on the roof of a Scania bus.

* On-board electric energy storage super or ultra capacitors - Mitrac.

- The PRIMOVE system uses Bombardier MITRAC Energy Saver which ensures continuous vehicle operation.
- Mitrac stores energy during braking and constantly charges during operation, picking up power from the underground section during OCS free operation. Enables OCS free operation over limited distances
- Combination of capacitors and storage cells.



*On-board electric energy storage super or ultra capacitors - Savannah.

- Developed and built by Electric Motor & Supply in Altoona Pennsylvania in 2008 in response to City of Savannah's requirements.
- 100% US.
- May operate with or without OCS.
- Based on Allen-Bradley distributed Rockwell Automation and other off the shelf components with some custom made devices.
- 100% super capacitor powered.
- Operating passenger service since February 2009.



On-board electric energy storage super or ultra capacitors - Savannah.



*On-board electric energy storage super or ultra capacitors - Savannah.

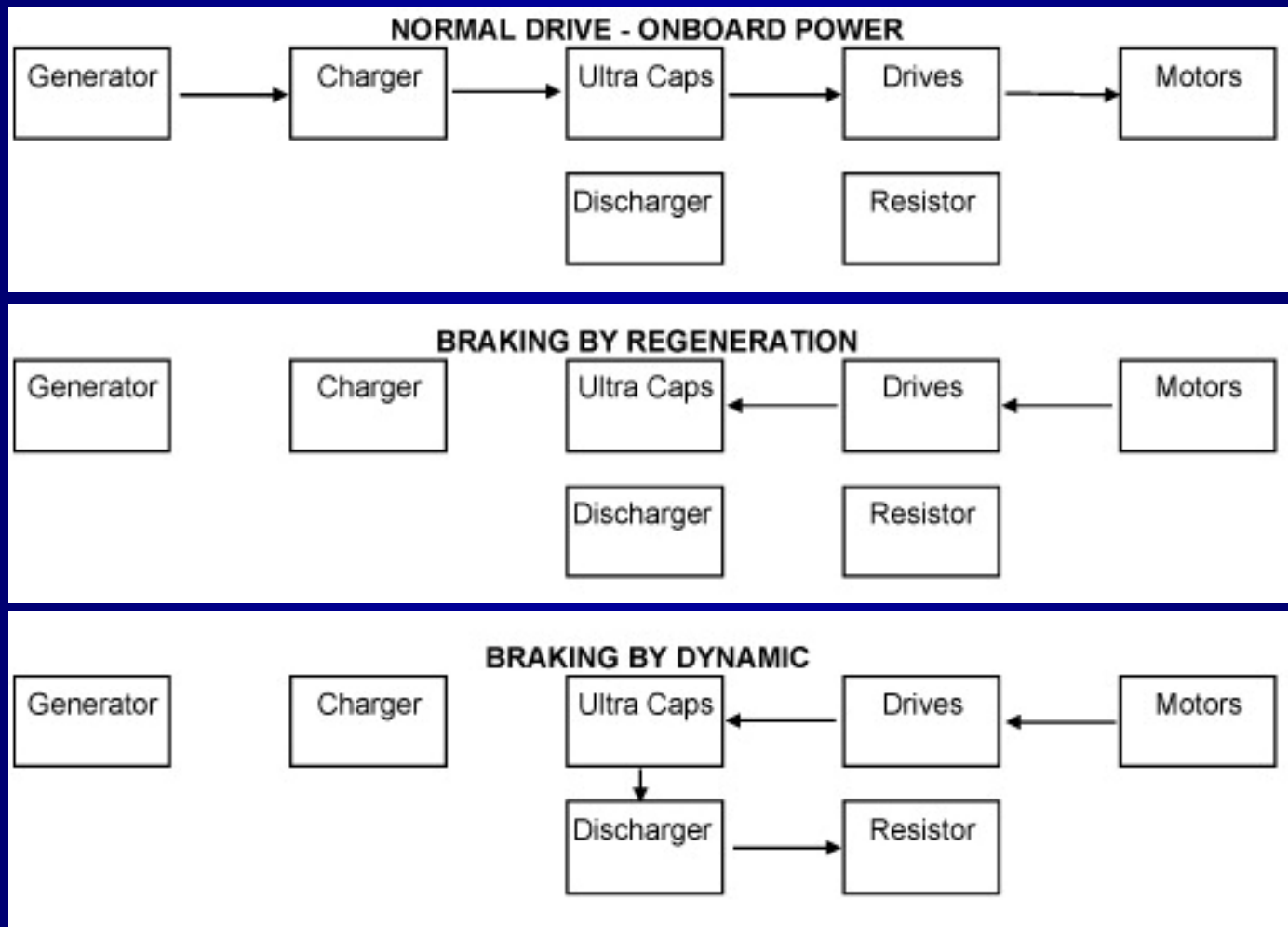

*On-board electric energy storage super or ultra capacitors - ACR.

Construcciones y Auxiliar de Ferrocarriles (CAF)
Rapid Charge Accumulator ACR (Spanish initials).

- CAF will install its new OCS free system along a 1.6 km of route of visual significance in Seville (Spain).
- The CAF joint venture has been selected to supply 13 low-floor trams with energy storage for Granada's (Spain) initial 15.9 km light rail route.
- Supply ACR solutions for Zaragoza (Spain) tramway. Zaragoza is currently developing a project for the construction of a tram network, half of which is equipped with an OCS system.

On-board electric energy storage super or ultra capacitors- ACR.

CAF ACR System

- Up to 1200 meters of OCS free running range depending on route characteristics between stops or incidents on the line .
- Modular and scalable .
- Suitable for use on existing systems
- 20 second charge times, compatible with stopping times at stations .
- Non-captive system (material/infrastructure independent) .

*On-board electric energy storage super or ultra capacitors- Sitras.

- Siemens Sitras system can operate without an overhead contact system for 2,500 meters.
- Can be retrofitted to existing vehicles, infrastructure remains unaffected.
- In Portugal, the system has been successfully used in passenger services since November 2008.
- Certified according to BoStrab (German Construction and Operating Code for Tramways).
- The system consists of double-layer capacitors and nickel-metal hydride batteries mounted on roof surfaces.

*On-board electric energy storage internal combustion engine – Tram/Train.

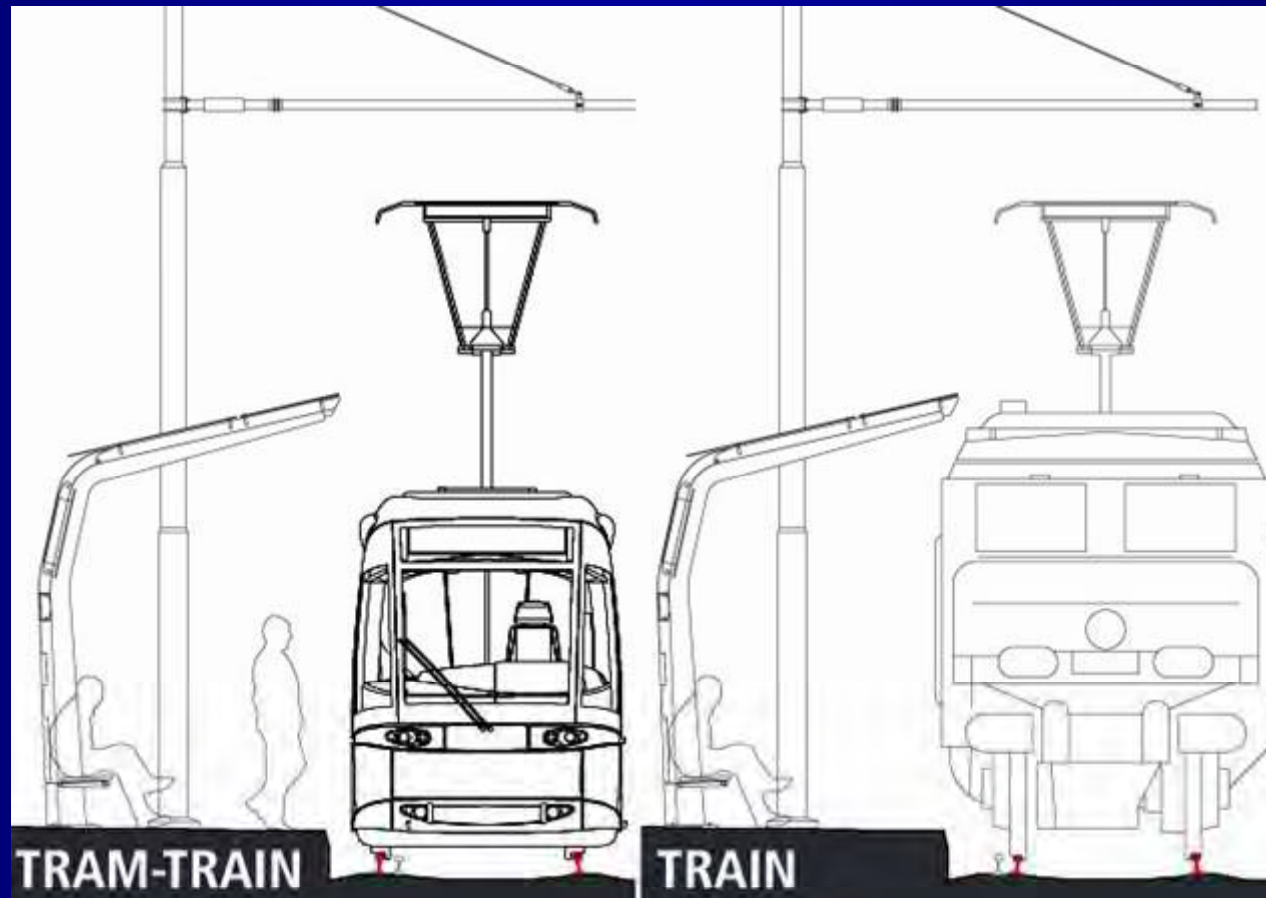

*On-board electric energy storage internal combustion engine – Tram/Train.

Alstom

Regio CITADIS (tram) and
CITADIS Dualis (Light Rail).

All current railway power
supply systems and high
performance diesel traction
may be incorporated. Full low
floor between the first and
last doors, Regio CITADIS
can carry up to 800
passengers.



*On-board electric energy storage (internal combustion engine, fuel cell).

Siemens

A Nordhausen (Germany) Siemens 'DUO' Combino linking the urban tramway, where it is electrically powered via overhead wires, and the rural railway, where it is powered by an onboard diesel engine.



*On-board electric energy storage fuel cell.

- No overhead Contact Line.
- Hybrid traction system onboard energy storage allows braking energy recovery and supplies power
- Hydrogen storage, compression and distribution in the maintenance facility.
- On-board hydrogen storage.

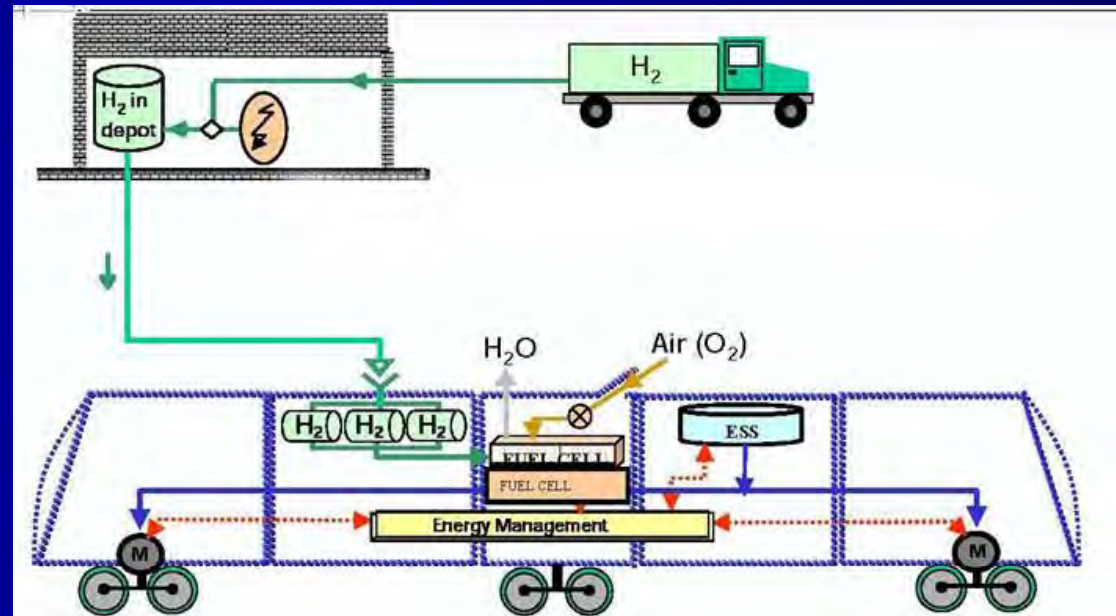

On-board electric energy storage fuel cell.

- State requirements and recommendations for future streetcar generations.
- Experimental streetcar in real operation conditions with passengers.
- Size and type of plant required.
- Production and distribution.
- Assess economical feasibility (Life Cycle Cost)
- Lifetime objective same as actual streetcar systems around 30 years.

*On-board electric energy storage

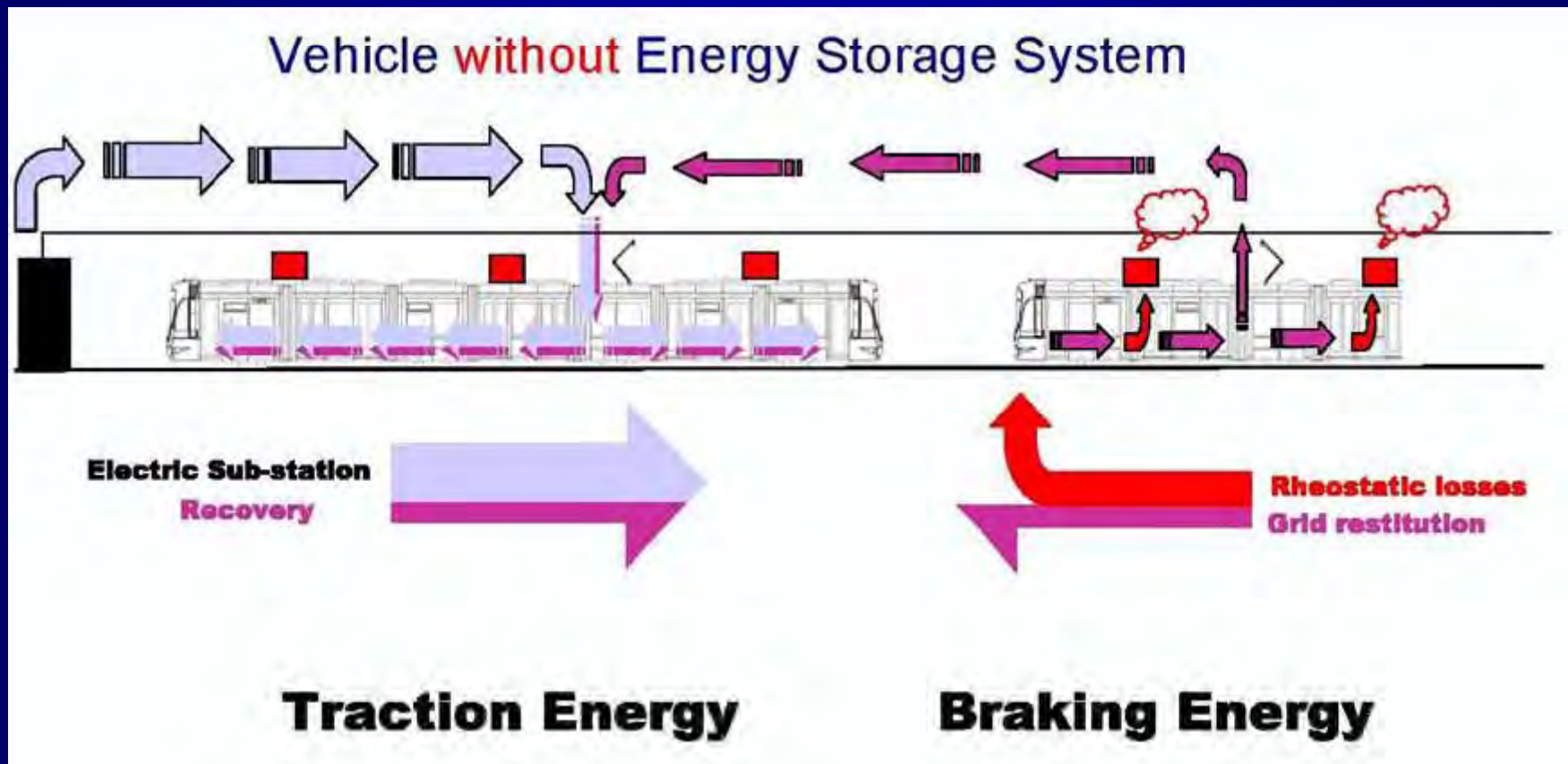

On-board electric energy storage

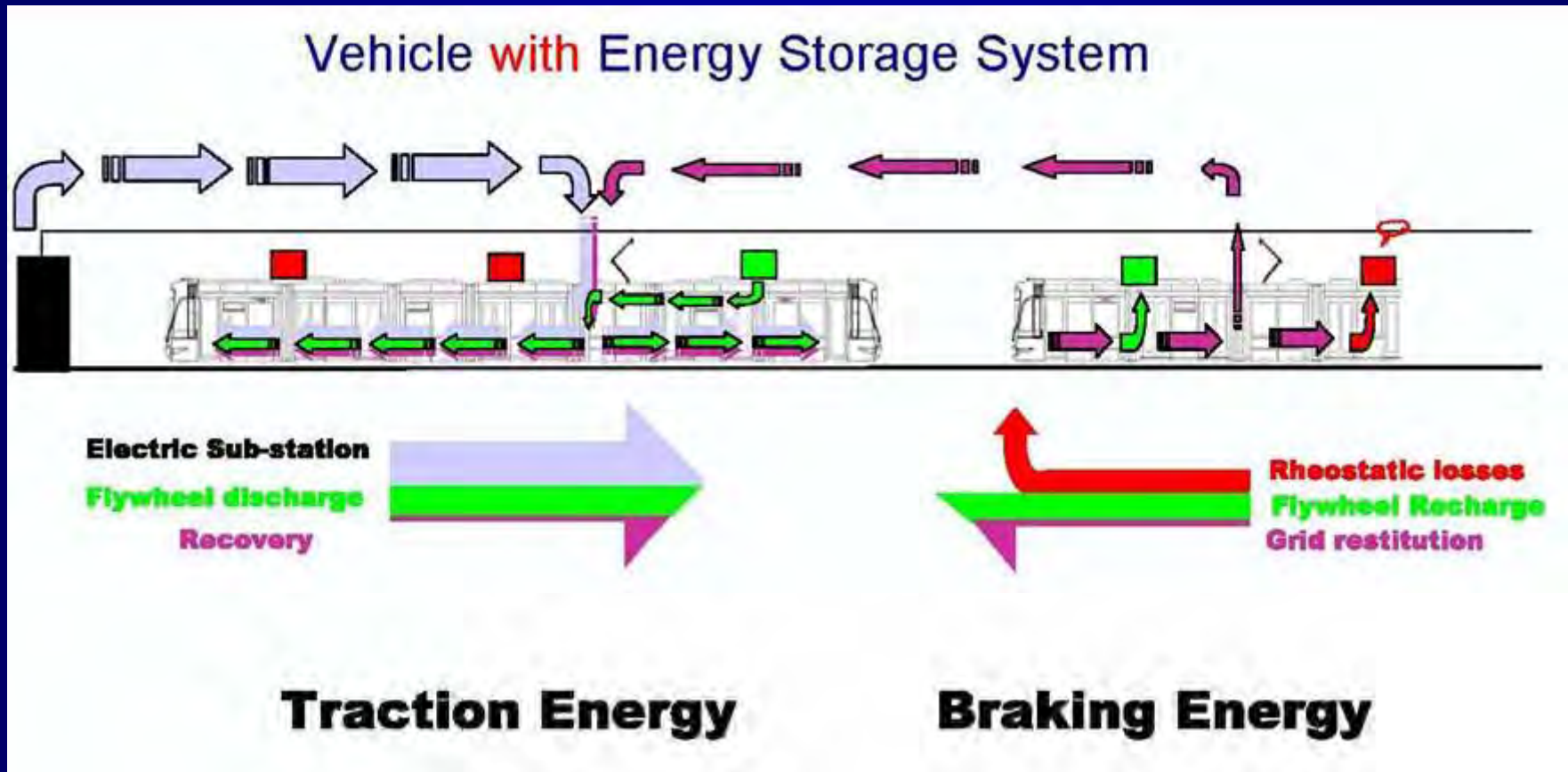

Energy Storage Technology

Martin P. Schroeder, P.E.

APTA Streetcar and Heritage Trolley Subcommittee
Chief Engineer, American Public Transportation Association

Energy Storage Benefits

- Braking Energy Capture
- Voltage Sag Correction
- Reduction of Line Energy Demand
- Power Leveling
- Reduction of Substations
- Wireless Operation

Voltage Sag Problems

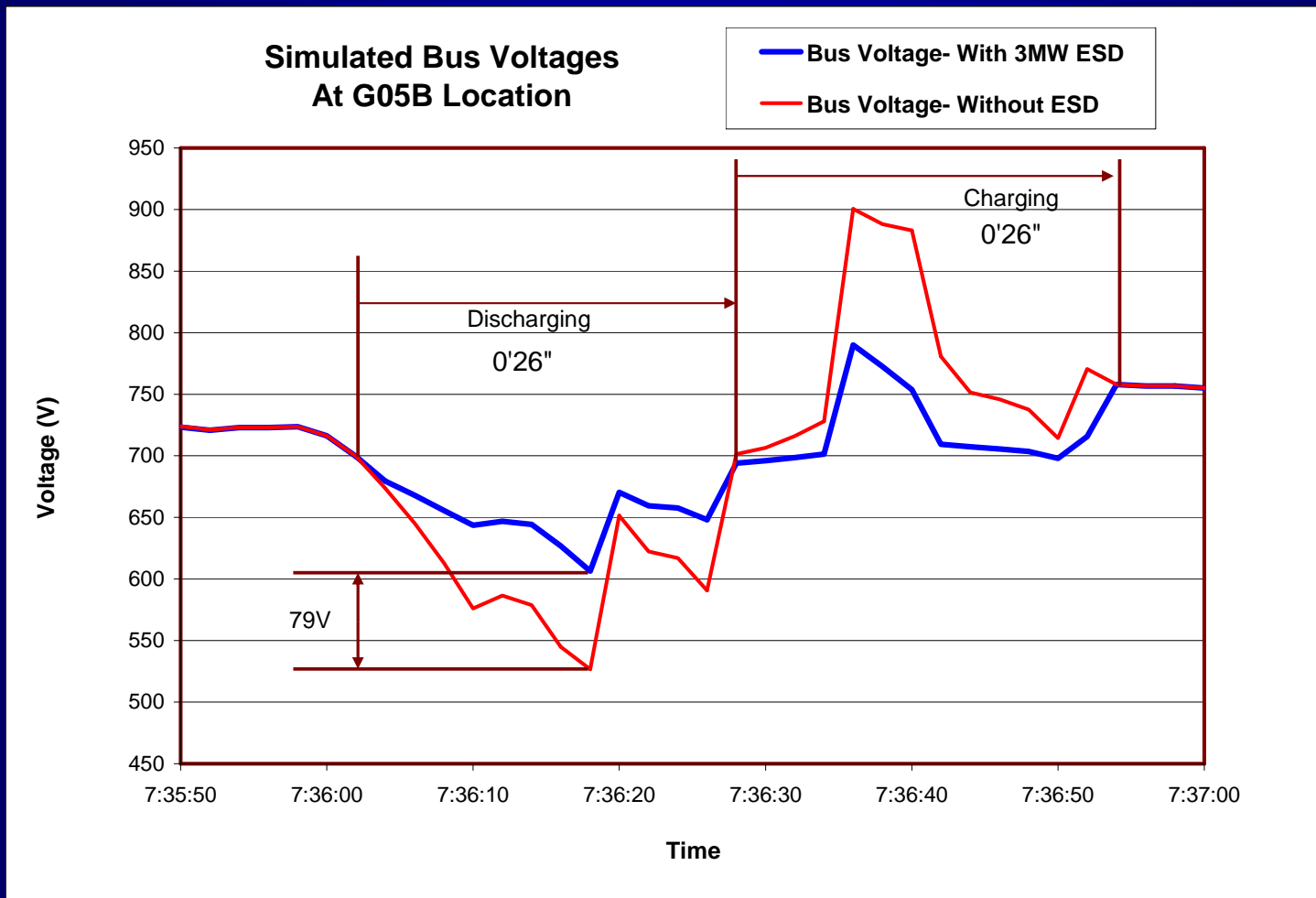

Peak Power Problems

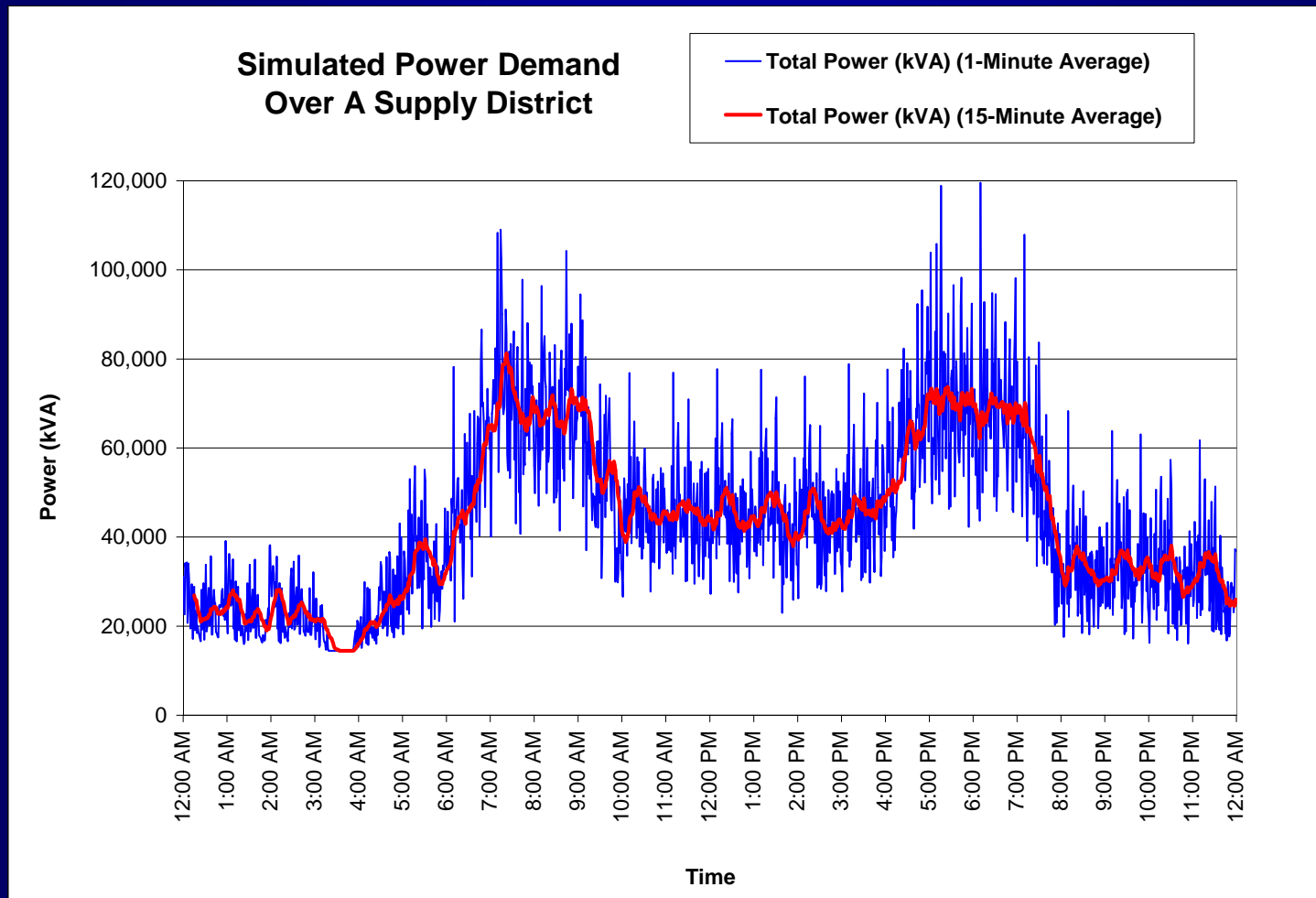

Example Types of Energy Storage

- Lead Acid
- Nickel Metal Hydride (NiMH)
- Lithium Ion (Li-ion)
- EC Capacitor
- Fuel Cells
- Flywheel
- Flow Batteries
- REDOX

Energy Storage Performance Measures

- Capacity
- Cycle Depth
- Cycle Frequency
- Voltage
- Internal Resistance Efficiency
- Operating Temperature
- Shelf Life
- Discharge and Charge Rates

Ragone Diagram

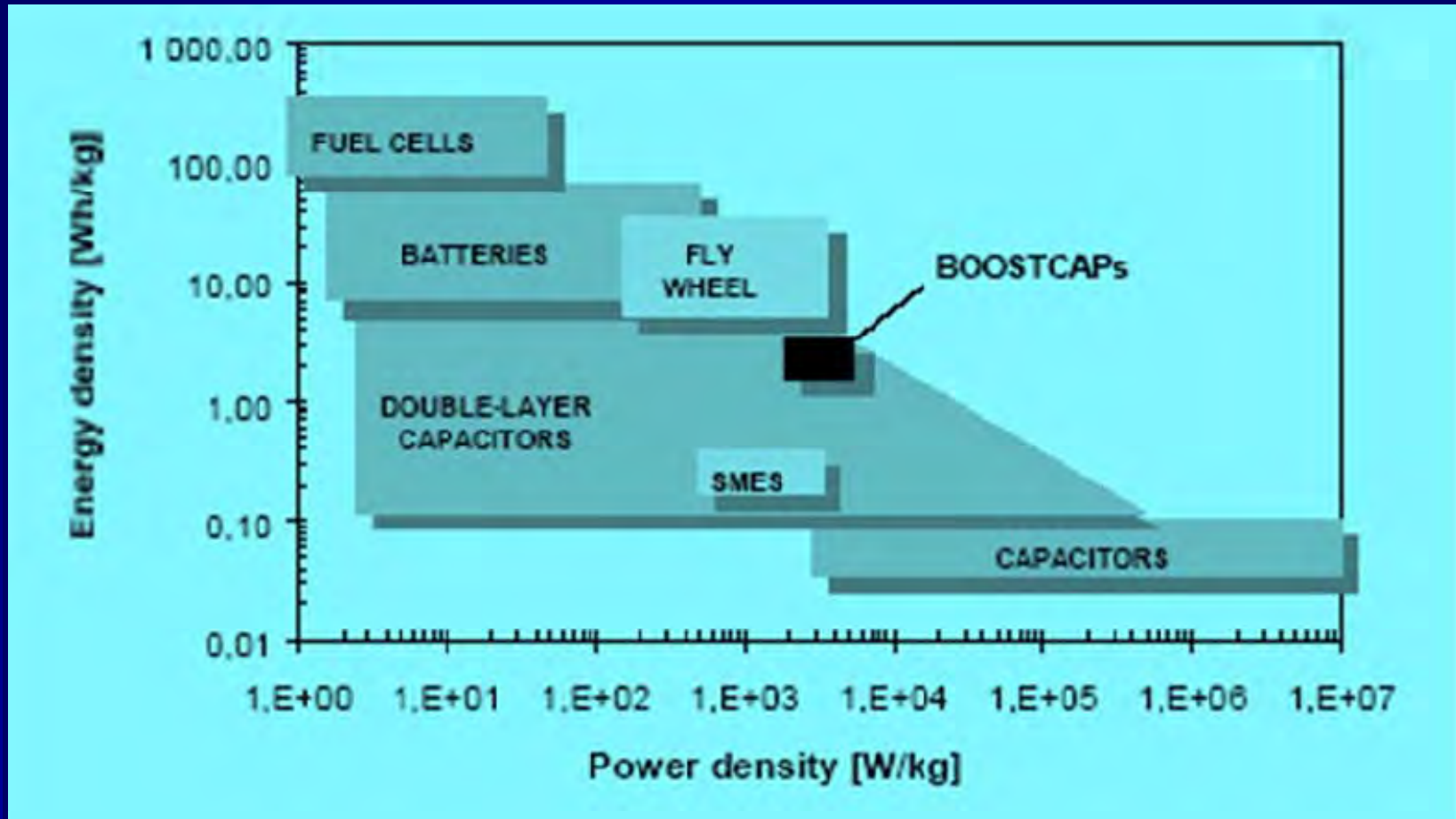

On-board electric energy storage (batteries, flywheels, super capacitors)

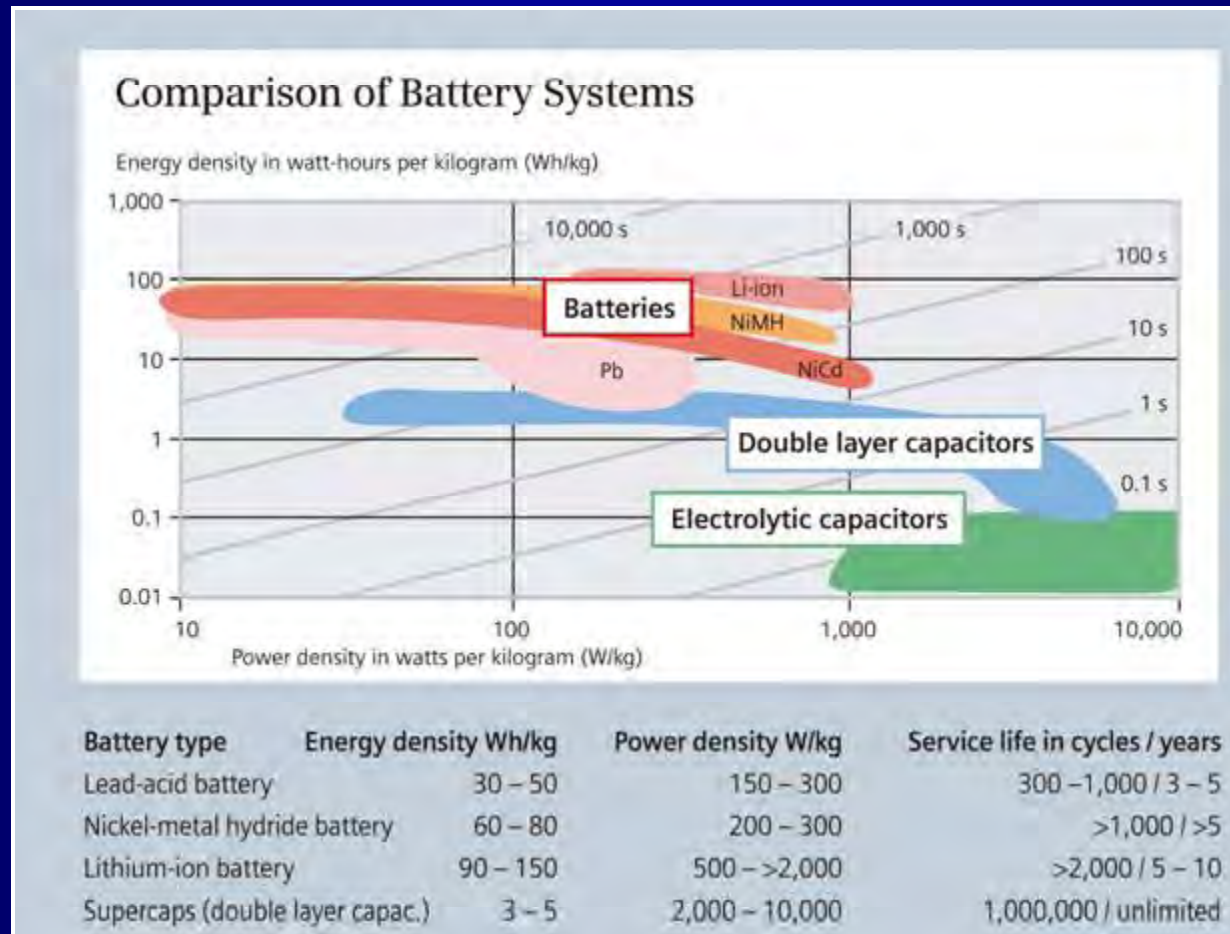

Energy Storage Cost Points

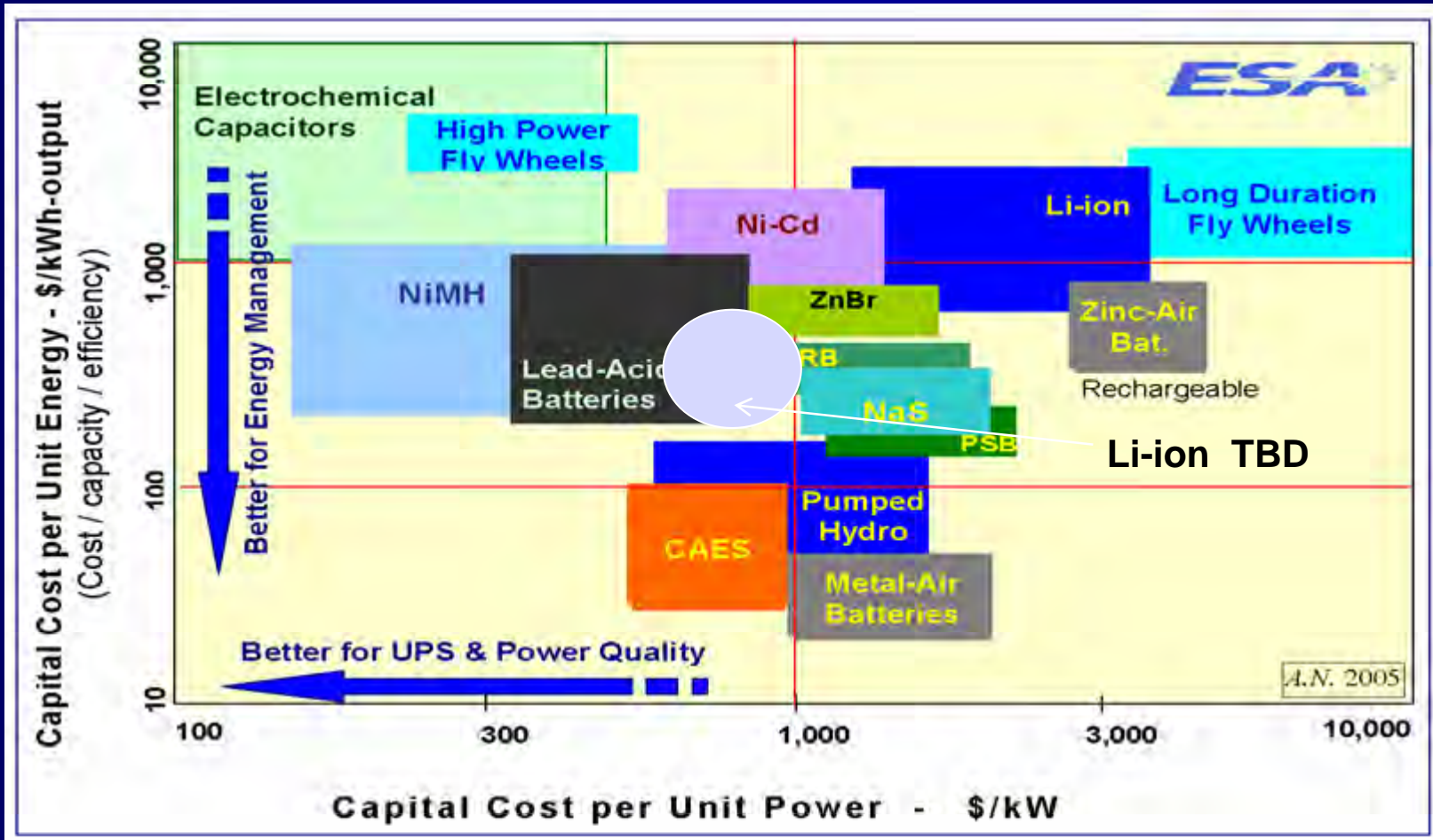

Energy Density

■ Nuclear	645,000,000
■ Automotive	8.10
■ Fuel Cell	1.62
■ Zinc Air Battery	1.33
■ Sodium Sulfur	0.77
■ Lithium Ion	0.54
■ Flywheel	0.5
■ NiMH	0.22
■ NiCd	0.14
■ Lead Acid	0.09
■ Redux	0.09
■ EC Capacitor	0.02
■ Spring	0.0003

For relative comparison only.

Advances in technology are changing capacities of these devices.

Possible Energy Storage Configurations

- Alignment
 - No Gap
 - Limited Gap
 - Full Storage
- Utilization of Regenerative Braking
- Power Quality & Voltage Sag Protection
- Efficiency



Putting it Together - Needs

- Alignment Definition
 - Terrain
 - Stops
 - Lengths between stations
 - Lengths of wireless operation
 - Ridership
- Vehicle Design
 - Storage
 - Regeneration
 - Efficiency
 - Maintenance

On-board Energy Storage Devices Receiving Significant Attention

- NiMH
- EC Capacitor
- Li-ion
- Hybrid – Battery / Capacitor
- Fuel Cell
- Flywheel

Practical Considerations

- Operations
- Maintenance
- Risk – Cost, Service, Experience, etc.
- Cost Investment / Payback
- Reliability
- Fit to Function

Implementation and Operations

T. R. Hickey, AICP

Vice Chair, APTA Streetcar and Heritage Trolley Subcommittee
Associate Vice President
Metropolitan Transit Authority of Harris County
Houston, Texas



APTA Streetcar and Heritage Trolley Subcommittee



American Public Transportation Association

SEPTA 



APTA Streetcar and Heritage Trolley Subcommittee



American Public Transportation Association

Operator's Checklist

- Safe?
- Reliable?
- Affordable?
- Sustainable?

Are the RISKS manageable?

A Tale of Two Agencies...



Risk Management

- Begins with a Risk Management Plan
 - FTA Risk Assessment Process
 - Design/construction risks
 - What events may occur to the detriment of the project?
 - Probability
 - How likely is it that each event will occur?
 - Financial risk
 - What would it cost to mitigate/recover from an occurrence?
 - Defined and managed through a Risk Register

Risk Management

- Risk Management vs. Risk Avoidance
 - Assess your risks
 - Don't shy away from emergent technologies
 - But maintain realistic skepticism
 - Have a 'B' Plan ready



Practical Experience

James H. Graebner

Chair, APTA Streetcar and Heritage Trolley Subcommittee
President, Lomarado Group
Denver, Colorado



Summary

	Visual Impact	Capital Cost	O&M Cost	Proprietary Technology	Proven Reliability	
POWER SUPPLY SYSTEMS						
Overhead Contact System	●	●	●	●	●	
Underground Conduit System	●	●	●	●	●	
Ground-Level Systems						
Contact	●	●	●	●	●	
Contactless	●	●	?	●	?	● No Issues
On-Board Generation						
Internal Combustion	●	●	●	●	●	● Minor Issues
Fuel Cells	●	?	?	?	?	● Major Issues
						? Unresolved
POWER STORAGE SYSTEMS						
Batteries	●	●	●	●	●	
Capacitors	●	●	●	●	●	
Flywheels	●	?	?	●	?	

Thank you



APTA Streetcar and Heritage Trolley Subcommittee



American Public Transportation Association